

# EXPLODED VIEW & PARTS LISTING

## Air Operated Double Diaphragm Pump

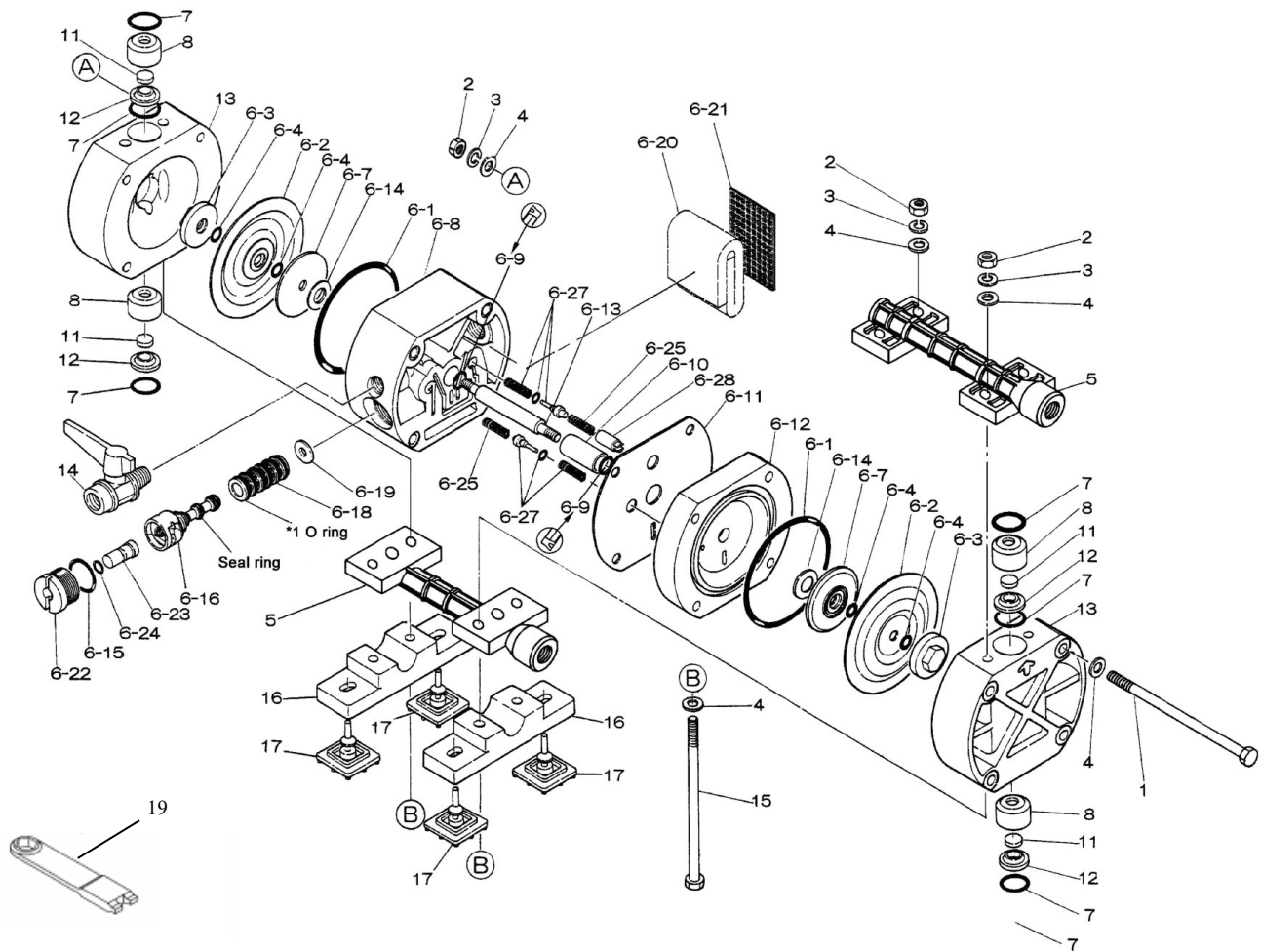

# EXPLODED VIEW & PARTS LISTING

## Air Operated Double Diaphragm Pump

Ref. No.	Part No.	Description	Qty.	Reorder
1	682748	BOLT	4	
2	628010	NUT	8	
3	681855	SPRING LOCK WASHER	8	
4	631328	PLAIN WASHER	16	
5	780053	MANIFOLD	2	
6	BODY ASSY.			
6-1	640139	O-RING	2	
6-2	771093	DIAPHRAGM	2	
6-3	771579	CENTER DISK	2	
6-4	643003	O-RING	4	
6-7	709317	CENTER DISK	2	
6-8	780006	BODY A	1	
6-9	685752	PACKING	2	
6-10	771088	BUSHING	1	
6-11	771980	GASKET	1	
6-12	780001	BODY B	1	
6-13	709316	CENTER ROD	1	
6-14	771239	CUSHION	2	
6-15	640017	O-RING	1	
6-16	802386	C-SPOOL VALVE ASSY.	1	
6-16 seal	771098	SEAL RING	5	
6-18	802049	SLEEVE ASSY.	1	
6-18-*1	771097	O-RING (SLEEVE O.D.)	6	
6-19	771096	CUSHION	1	
6-20	771465	SILENCER	1	
6-21	771589	MESH	1	
6-22	771100	CAP	1	
6-23	771099	RESET BUTTON	1	
6-24	640002	O-RING	1	
6-25	709319	SPRING	2	
6-27	803510	PILOT VALVE ASSY.	2	
6-27-*1	640000	O-RING (PILOT VALVE ASSY.)	2	
6-28	771095	STOPPER	1	
7	643015	O-RING	6	
8	771581	VALVE STOPPER	4	
11	771094	FLAT VALVE	4	
12	772735	VALVE SEAT	4	
13	780232	OUT CHAMBER	2	
14	683055	BALL VALVE	1	
15	682747	BOLT	4	
16	771648	BASE	2	
17	771102	CUSHION	4	
19	771132	ACCESSORY TOOL	1	
KIT	K5-VT-2	LIQUID SIDE KIT		
KIT	K5-AM	AIR MOTOR KIT		

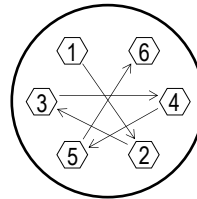

### Tightening torque for center rod and out chambers.

Center Rod 65 in-lbf {7.4 N-m}  
 Out Chambers 65 in-lbf {7.4 N-m}

### Tightening torque for manifold retainer bolts.

FVT 65 in-lbf {7.4 N-m}

### General Tools:

- Socket wrench - 10mm
- Open-end wrenches - 10mm
- Plyer

### Miscellaneous:

- Assembly Oil - turbine oil class 1 - no additives (equivalent to ISA VGA32 grade)
- Nuts - M6 x 1
- Urea grease grade (NLGI) No. 2

### Customer Notes

Model #: \_\_\_\_\_  
 Description: \_\_\_\_\_  
 Serial #: \_\_\_\_\_  
 Date Installed: \_\_\_\_\_  
 Department Location: \_\_\_\_\_  
 Tag/Project: \_\_\_\_\_

# EXPLODED VIEW & PARTS LISTING

## Air Operated Double Diaphragm Pump

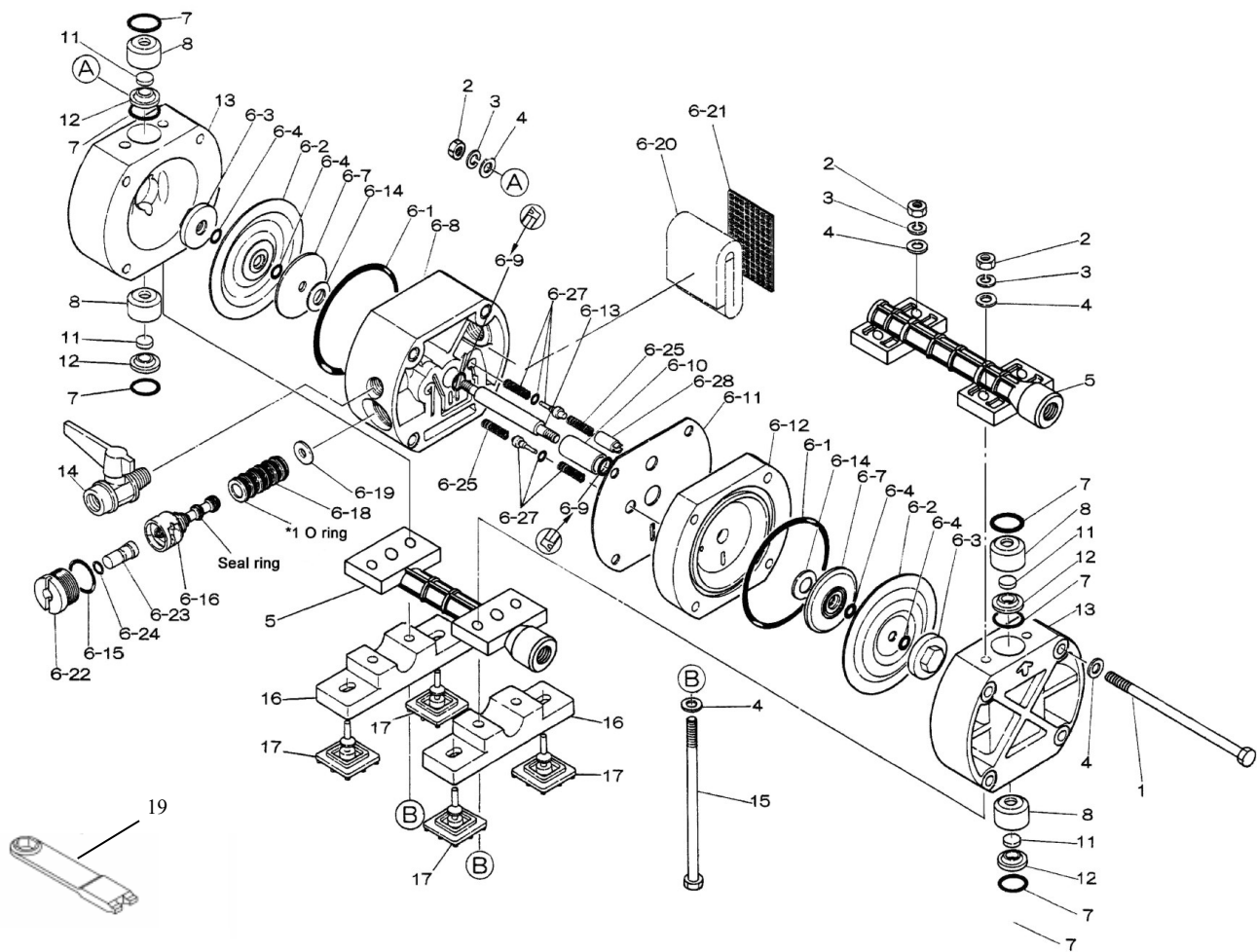
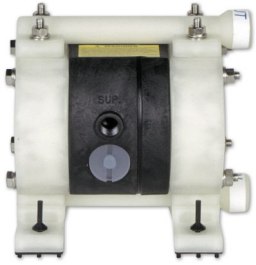

# EXPLODED VIEW & PARTS LISTING

## Air Operated Double Diaphragm Pump

REF. No.	PART No.	DESCRIPTION	QTY.	REORDER
1	682748	BOLT	4	
2	628010	NUT	8	
3	681855	SPRING LOCK WASHER	8	
4	631328	PLAIN WASHER	16	
5	780133	MANIFOLD	2	
6	802594	BODY ASSY.	1	
6-1	640139	O-RING	2	
6-2	771093	DIAPHRAGM	2	
6-3	771089	CENTER DISK	2	
6-4	643003	O-RING	4	
6-7	709317	CENTER DISK	2	
6-8	780006	BODY A	1	
6-9	685752	PACKING	2	
6-10	771088	BUSHING	1	
6-11	771980	GASKET	1	
6-12	780001	BODY B	1	
6-13	709316	CENTER ROD	1	
6-14	771239	CUSHION	2	
6-15	640017	O-RING	1	
6-16	802386	C-SPOOL VALVE ASSY.	1	
6-16 seal	771098	SEAL RING	5	
6-18	802049	SLEEVE ASSY.	1	
6-18-*1	771097	O-RING (SLEEVE O.D.)	6	
6-19	771096	CUSHION	1	
6-20	771465	SILENCER	1	
6-21	771589	MESH	1	
6-22	771100	CAP	1	
6-23	771099	RESET BUTTON	1	
6-24	640002	O-RING	1	
6-25	709319	SPRING	2	
6-27	803510	PILOT VALVE ASSY.	2	
6-27-*1	640000	O-RING (PILOT VALVE ASSY.)	2	
6-28	771095	STOPPER	1	
7	643015	O-RING	6	
8	772655	VALVE STOPPER	4	
11	771094	FLAT VALVE	4	
12	772738	VALVE SEAT	4	
13	780231	OUT CHAMBER	2	
14	686826	BALL VALVE	1	
15	682747	BOLT	4	
16	771101	BASE	2	
17	771102	CUSHION	4	
19	771132	ACCESSORY TOOL	1	
KIT	K5-PT-2	LIQUID SIDE KIT		
KIT	K5-AM	AIR MOTOR KIT		

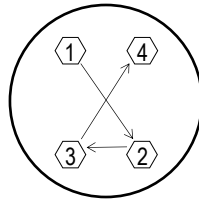

### Tightening torque for center rod and out chambers.

Center Rod 65 in-lbf {7.4 N-m}  
 Out Chambers 65 in-lbf {7.4 N-m}

### Tightening torque for manifold retainer bolts.

FPT 65 in-lbf {7.4 N-m}

### General Tools:

- Socket wrench - 10mm
- Open-end wrenches - 10mm
- Plyer

### Special Tools (sold separately):

- Cap and disk remover (771132)
- Sleeve remover (713148)

### Miscellaneous:

- Assembly Oil - turbine oil class 1 - no additives (equivalent to ISA VGA32 grade)
- (equivalent to ISO VGA32 grade)
- Nuts - M6 x 1
- Urea grease grade (NLGI) No. 2

### Customer Notes

Model #: \_\_\_\_\_  
 Description: \_\_\_\_\_  
 Serial #: \_\_\_\_\_  
 Date Installed: \_\_\_\_\_  
 Department Location: \_\_\_\_\_  
 Tag/Project: \_\_\_\_\_