

Technical documentation

SCN Series: **SCN 20 / SCN 25 / SCN 40**

SCN-D Series: **SCN 25-D / SCN 40-D**



SOMA Pumps GmbH
Seestraße 1
74232 Abstatt
Tel.: 07062 / 91 58 83-33
Fax.: 07062 / 91 5883-59
Email: info@soma-pumps.de

Table of contents

1	GENERAL INFORMATIONS	7
1.1	Definition of this Technical Documentation	7
1.2	Copyrights, property rights	7
1.3	Handling the technical documentation	7
1.4	Safety information in these instructions	8
1.5	Functional principle	9
2	SAFETY.....	10
2.1	Basic safety information	10
2.2	Organisational measures	11
2.3	Responsibility of the operating company for safety	11
2.3.1	Duties of the operating company	11
2.3.2	Selection and qualification of personnel	12
2.3.3	Personnel-related duties of the operating company	15
2.3.4	Duties of personnel themselves.....	15
2.3.5	Personal protective equipment	15
2.4	Safety information about special types of danger	15
2.4.1	Electrical energy.....	15
2.4.2	Notes on drive and inverter	16
2.4.3	Electrical equipment, general	17
2.4.4	Hazard posed by dangerous goods	18
2.4.5	Hazard posed by pump	18
3	PUMP SPECIFICATIONS.....	20
3.1	Technical data.....	20
3.1.1	SCN Series	20
3.1.2	SCN-D Series.....	20
3.1.3	Pressure ratios	20
3.2	Intended use.....	20
3.3	Improper use	20
4	SETTING UP THE PUMP.....	21

4.1	Potentially explosive environment (ATEX)	21
4.2	Connector position	21
4.3	Rotating connections	22
4.3.1	SCN Serie	22
4.3.2	SCN-D Serie	22
4.4	Changing rotational direction	23
4.5	Coupling to pipeline	23
4.6	Commissioning	24
4.7	Introduction	24
4.8	Safety instructions for specialists	25
4.9	Preparation of maintenance work	25
4.10	Oil change and fill quantity, SCN Series	26
4.11	Changing spare parts	27
4.12	Servicing of bearings	27
4.13	Adjustment dimension "X"	27
4.13.1	SCN Series	27
4.13.2	SCN-D Serie	29
4.14	Error description	31
4.14.1	SCN Serie	31
4.14.2	SCN-D Serie	32
5	DECOMMISSIONING, DISMANTLING AND DISPOSAL	35
5.1	Decommissioning, dismantling	35
5.2	Disposal	35
6	FLUSHING AND CLEANING	36
6.1	Flushing	36
6.1.1	SCN Series	36
6.1.2	SCN-D Serie.....	36
6.2	Cleaning in own circuit	36
6.3	Cleaning by hand	36

6.4	Cleaning in the CIP circuit	37
6.5	Sterilisation	37
6.5.1	SCN Serie	38
6.5.2	SCN-D Serie	39
7	ASSEMBLY - DISASSEMBLY - TRANSPORT	40
7.1.1	Delivery	40
7.1.2	Checking the delivery for completeness	40
7.1.3	Safety instructions	40
7.2	Dismantling the pump head.....	41
7.2.1	Pump head of the SCN Series.....	41
7.2.2	Removal of sealing system SCN Series.....	42
7.2.3	Dismantling the pump head of the SCN-D Series.....	44
7.2.4	Removal of sealing system SCN-D Series	45
8	SECTIONAL DRAWING WITH PARTS LIST	47
8.1	SCN20 with parts list.....	47
8.2	SCN25 / SCN40 with parts list	48
8.3	SCN25D / SCN40D with parts list	49
8.4	Face seal	50
8.4.1	Face seal SCN20	50
8.4.2	Face seal SCN25 / SCN40	50
8.4.3	Face seal SCN25D / SCN40D.....	51
8.5	Shaft sealing ring system	52
8.5.1	Shaft ring seal (3x) SCN / SCN-D Serie.....	52
8.6	Dimensioned drawing.....	53
8.6.1	SCN Series	53
8.6.2	SCN D Series	53
9	STATIC RINSING EQUIPMENT	55
10	INDEX	56
10.1	List of figures	56
10.2	List of tables	56

EU-Declaration of conformity

In the sense of the EC Machinery Directive 2006/42/EC,

Manufacturer / Distributor SOMA Pumps GmbH
Seestraße 1
74232 Abstatt

We hereby declare that the following product:

Product description **SOMA SINUS SODIAL®**
Type designation: _____
Serial number: _____
Year of manufacture: _____

complies with the applicable essential requirements of the EC Machinery Directive 2006/42/EC.

The machine must not be put into service until it has been determined that it complies with the provisions of the Machinery Directive (2006/42/EC).

Directives:

2006/42/EG Machinery Directive
2014/35/EU Low Voltage Directive

Standards:

EN 60204-1 Safety of machinery - Basic concepts, Electrical equipment of machines.
DIN EN ISO 12100 Safety of machinery - Basic concepts, general principles for design, Part1:Basic terminology, methodology.
DIN EN 809:2012-10 Pumps and pump units for liquids - General safety requirements.
DIN 31000:2017-04 General guidelines for the safety-related design of products.
DIN EN 10357:2014-03 Austenitic, austenitic-ferritic and ferritic longitudinally welded stainless steel pipes for the food and chemical industry.

The special technical documents belonging to the complete machine according to Annex VII Part A have been prepared.

Place, date/signature: Abstatt,
Signatory details:

EG-Installation declaration

In the terms of the EC Machinery Directive 2006/42/EC, Annex II B

Manufacturer / Distributor SOMA Pumps GmbH
 Seestraße 1
 74232 Abstatt

We hereby declare that the following product:

Product description	SOMA SINUS SODIAL®
Type designation:	SCN20
Serial number:	1509
Year of manufacture:	2023

complies with the applicable essential requirements of the EC Machinery Directive 2006/42/EC.

The partly completed machinery must not be put into service until it has been established that the machinery into which the partly completed machinery is to be incorporated complies with the provisions of the EC Machinery Directive 2006/42/EC:

Directives:

2006/42/EG	Machinery Directive
2014/35/EU	Low Voltage Directive

Standards:

EN 60204-1	Safety of machinery - Basic concepts, Electrical equipment of machines.
DIN EN ISO 12100	Safety of machinery - Basic concepts, general principles for design, Part1:Basic terminology, methodology.
DIN EN 809:2012-10	Pumps and pump units for liquids - General safety requirements.
DIN 31000:2017-04	General guidelines for the safety-related design of products.
DIN EN 10357:2014-03	Austenitic, austenitic-ferritic and ferritic longitudinally welded stainless steel pipes for the food and chemical industry.

The special technical documents belonging to the partly completed machinery according to Annex VII Part B have been prepared.

Place, date/signature:
 Signatory details:

Abstatt, 20.03.2023



1 General informations

1.1 Definition of this Technical Documentation

Notice !	
	<p>The pump series SCN is delivered without drive and is therefore considered an "incomplete machine". For this series, this documentation applies as "installation instructions". The declaration of incorporation applies to this pump series.</p> <p>The pump series SCN-D is delivered with drive and is therefore considered a "complete machine". For this series, this documentation applies as "Operating Instructions". The Declaration of Conformity applies to this pump series.</p> <p>In the following, the term "Technical Documentation" is used.</p>

1.2 Copyrights, property rights

The copyright of this technical documentation remains with SOMA Pumps GmbH. This documentation is only intended for the operator of the complete system and his personnel for internal use.

The supplementary equipment-specific technical documentation contains descriptions, technical drawings, regulations and notes which may not be reproduced, distributed or otherwise communicated, in whole or in part, or used for competitive purposes without authorisation.

All rights reserved, in particular in the event of patents being granted or other registrations. We reserve the right to make technical changes.

1.3 Handling the technical documentation

This documentation is intended for the system operator.

This manual contains important information on how to safely and properly install, transport, commission, operate and maintain the pump and how to rectify simple faults yourself.

Read these instructions completely and in particular chapter 2.1 "Basic safety instructions".

SOMA Pumps GmbH declines all liability for damage caused by failure to observe instructions on the pump or in the documentation.

This Technical Documentation must be supplemented by the user of the machine with instructions based on existing national regulations for accident prevention and environmental protection.





Also observe generally applicable, legal and other binding regulations of European or national legislation as well as the regulations on accident prevention and environmental protection applicable in your country.

Repair work must be carried out in time and only by qualified personnel!

Observance of the safety instructions protects against danger to life and limb and reduces the risk of improper use of the machine. Pay attention to the warning signs on the machine without exception. Replace missing or damaged signs immediately.

1.4 Safety information in these instructions

In this documentation, safety information appears before an action sequence where there is a risk of damage to property or injury to persons. The described measures for preventing the hazard must be observed.

Danger !	
	Signal word, indicates a situation of immediate danger, which, if not avoided, will result in death or serious injury.
Warning !	
	Signal word, indicates a potentially dangerous situation, which, if not avoided, could result in minor or moderate injury.
Caution !	
	Signal word, indicates a potentially dangerous situation, which, if not avoided, could result in minor or moderate injury.
Note !	
	This symbol does not indicate safety information, but offers guidance to better understand machine processes.

Safety information is structured as follows:

- **Warning sign:** Draws attention to the danger.
- **Signal word:** Specifies the severity of the danger.
- **Type and source of the danger:** Identifies the type and source of the danger
- **Consequences:** Describes the consequences of non-observance.
- **Preventative action:** Specifies how to avoid the danger.

1.5 Functional principle

The SINUS displacement pump impresses with its simple yet effective functional principle. The rotor, which is made of stainless steel, is the beating heart of the pump. It sits on the pump shaft with its circular SINUS curve disc and transports the product gently and virtually without pulsation in four evenly distributed chambers.

A scraper, which is installed for sealing, divides the pump into pressure and suction sides, thus helping to distinctly separate the two chambers and enhance the resulting, excellent suction characteristics of the pump.

2 Safety

2.1 Basic safety information

The SCN / SCN-D series has been manufactured according to the generally recognised rules of technology. Despite this, there is still a risk of injury to persons and damage to property if the following basic safety information and the warnings before action instructions in this manual are not observed.

- Only use the pumps if in technically perfect condition.
- Only use the pumps as intended, with due consideration of safety and of the dangers, and with full observance of the assembly instructions.
- Rectify any malfunctions that might impair safety immediately.
- Keep this manual in a place where it is accessible to all users at all times.
- When carrying out work such as installation, commissioning, operation, changing of usage conditions and operating methods, and maintenance and servicing of the pumps, you must observe the disconnection procedures described in the assembly instructions.

The assembly instructions and the safety requirements of these assembly instructions comply with EC Machinery Directive 2006/42/EC.

Further directives and European standards applied can be found if applicable in the installation declaration.

2.2 Organisational measures

The assembly instructions must be kept at hand at the place of use of the machine at all times.

In addition to the contents of the assembly instructions, generally accepted, local and other mandatory rules and regulations on accident prevention and environmental protection must be observed.

Personnel assigned by the operator to activities on the plant must have read and understood the assembly instructions and in particular Chapter "Safety" before commencing work.

The activities of personnel must be checked at irregular intervals to ensure safe and diligent performance in due consideration of potential hazards.

All safety instructions and danger warnings at and on the plant must be:

- strictly observed
- kept legible

In the event of safety-related changes to the pump or changes in operating behaviour, the plant must be switched off immediately. The malfunction must be reported to the competent person or body designated by the operator and corrected immediately. Furthermore, the pumps must not be modified, added to or converted without the approval of manufacturer SOMA Pumps GmbH. Spare parts must meet the technical requirements defined by SOMA Pumps GmbH.

This is guaranteed when original spare parts are used.

In order to carry out maintenance measures, it is essential to have workshop equipment appropriate to the work.

2.3 Responsibility of the operating company for safety

2.3.1 Duties of the operating company

The pumps are used in commercial applications.

The operator of the plant is therefore subject to legal obligations regarding work safety.

In addition to the safety instructions in this manual, the safety, accident prevention and environmental protection regulations applicable to the area of use of the machinery must be complied with.

2.3.2 Selection and qualification of personnel

Work on and using the plant is allowed to be carried out only by appropriate, suitably trained personnel. You must only use trained and instructed persons. All of the operating and maintenance personnel must be fully trained and instructed about possible dangers and must know and observe the safety information in the assembly instructions.

The knowledge of a trained expert is required for installation, servicing, and maintenance work. Work on electrical systems, components, and devices is allowed to be carried out only by a specialist electrician or by a specially instructed person under the guidance and supervision of a specialist electrician in accordance with electrical engineering rules.

Note !	
	<p>An expert is a person who, due to his or her expert training, knowledge, and experiences as well as knowledge of applicable conditions, is able to assess work entrusted to him or her, recognise possible dangers, and implement appropriate safety measures. An expert must observe the applicable technical regulations.</p>

Warning !



Risk associated with inadequate skills of personnel!

Inadequately skilled personnel being unable to assess the risks posed by machinery can lead to situations with the potential for serious injury or death.

All work is allowed to be carried out only by appropriately qualified personnel.

Keep insufficiently qualified personnel out of the work area.

Personnel who are being trained, taught, or instructed, or are taking part in general training, are allowed to work on the plant only if constantly supervised by a suitable person.

Auxiliary personnel who carry out cleaning and maintenance tasks, for example, must also be instructed in all safety provisions. They are allowed to work only under the constant supervision of specialist personnel.

The operating company must instruct all persons who work on the plant at least once a year on the observance of these assembly instructions and, in particular, the safety regulations. Records of instruction given must be kept.

These instructions name the following personnel qualification levels for the various tasks.

Instructed personnel / auxiliary personnel:

Instructed personnel have been informed by the operating company in formal training of the tasks assigned to them and of the potential dangers associated with improper conduct.

Operator:

The operator has been notified by the operating company in formal training of the tasks assigned to him/her and of the potential dangers associated with improper conduct. The operator may perform tasks that go beyond normal operation only if such tasks are indicated in this manual and the operating company has explicitly entrusted the operator with such.

Qualified personnel:

Qualified personnel means persons who have been authorised by the designated safety officer on the basis of their professional training, experience, instruction and knowledge of relevant standards and regulations, accident prevention regulations and operating conditions.

Specialist personnel/expert:

In the sense of accident prevention regulations, an expert is a person who, due to his or her expert training, knowledge, and experiences as well as knowledge of applicable norms and provisions, is able to carry out and assess the work entrusted to him or her and recognise and prevent possible dangers independently.

Mechanic:

A mechanic has undergone skilled training for the relevant field of work, has special knowledge and experience, and is aware of the applicable norms and provisions. He or she is therefore able to carry out work on plants/mechanical machines and components and to recognise and prevent possible dangers independently.

Electrician/specialist electrician:

In the sense of accident prevention regulations, a specialist electrician is a person who, due to his or her expert training, knowledge, and experiences as well as knowledge of applicable norms and provisions, is able to carry out and assess the work entrusted to him or her on electrical systems and to recognise and prevent possible dangers.

2.3.3 Personnel-related duties of the operating company

The operating company undertakes to only have persons working on the plant who:

- are familiar with the basic rules on safety at work and accident prevention and are instructed in the handling of the plant/machinery.

2.3.4 Duties of personnel themselves

All persons who are assigned to work on the machinery undertake prior to commencing work:

- to comply with the basic rules on safety at work and accident prevention.
- to read Chapter 2 Safety and the warning information in this operating manual before commencing work and to ensure that this is followed at all times during work.
- to wear the personal protective equipment stipulated by the operating company.

The safety rules and warnings must be confirmed as having been read and understood by signing. The form must be provided by the operating company.

2.3.5 Personal protective equipment



Safety footwear



Eye protection





Gloves



Hearing protection

2.4 Safety information about special types of danger

2.4.1 Electrical energy

Danger !	
 	<p>Danger due to electrical voltage!</p> <p>On electrical systems and equipment, electrical voltages that can result in serious injury or even death can occur.</p> <p>Work on electrical systems or equipment (electrical components and devices) is allowed to be carried out only by a specialist electrician or instructed person under the supervision of a specialist electrician in accordance with electrical engineering rules.</p> <p>Insulated tools must be used for work on electrical system parts.</p>

The following measures must be strictly observed:

- In the case of disruptions to the electrical power supply, the machine must be switched off immediately.
- If required and/or necessary, machine components that are being inspected, serviced or repaired must be disconnected from the electricity supply and secured against reconnection.
- The disconnected components must first be tested to ensure disconnection from the electricity supply, then grounded and short-circuited. In addition, adjacent parts that are connected to the electricity supply must be isolated.
- The electrical equipment of the machinery must be tested regularly. Defects, such as loose connections or faulty cables, must be rectified immediately.
- If work is required on live parts, a second person must be present in order to activate the EMERGENCY OFF function or the main switch to disconnect the electricity supply if an emergency occurs. Cordon off the working area with a red and white safety cordon. Display a warning sign.
- Only original fuses with the prescribed amperage may be used.
- Use only insulated tools.



2.4.2 Notes on drive and inverter

Caution !	
	<p>Danger due to electrical voltage!</p> <ul style="list-style-type: none"> • Check the frequency of the supply voltage. If the frequency of the supply voltage differs from the standard frequency, consult the manufacturer's documentation. • Do not perform an applied voltage test on the frequency inverter! • If this should be necessary, first contact the manufacturer. • Do not touch the frame of the frequency inverter and the housing directly. These components can become very hot during and after operation.



Note !	
	<p>If you have any problems or questions about the drive or frequency inverter, always refer to the documents supplied by the supplier.</p>

2.4.3 Electrical equipment, general

The used electrical components and devices are equipment for use in industrial machines.

Danger !	
 	<p>Danger due to electrical voltage!</p> <p>Electrical equipment (components and devices) carry an electrical voltage during operation. Coming into contact with these live parts will directly result in severe injuries or even death.</p> <p>The removal of the required machine cladding is prohibited.</p> <p>The improper use of the machine and any part thereof is prohibited. You must ensure the proper servicing of the machine and all of its parts. The operating company must ensure that the machine is operated properly and by qualified personnel.</p> <p>Only qualified persons are allowed to carry out work on the components and devices. Personnel who work or perform tasks on the machine must always have the delivered assembly instructions and other product documentation at hand when carrying out all relevant work. The personnel must consistently observe the provisions of these assembly instructions.</p> <p>All unqualified persons are prohibited from carrying out work on the components/devices or in their vicinity.</p>

If the power supply has to remain switched on during certain activity on the machine, appropriate measures must be taken to ensure that it is not possible to inadvertently trigger system/machine functions.

Danger !	
 	<p>Danger from electromagnetic fields!</p> <p>The removal of the required machine cladding is prohibited.</p> <p>The improper use of the machine and any part thereof is prohibited.</p> <p>You must ensure the proper servicing of the machine and all of its parts.</p>

	<p>The operating company must ensure that the machine is operated properly and by qualified personnel.</p> <p>Only qualified persons are allowed to carry out work on the components and devices.</p> <p>Personnel who work or perform tasks on the machine must always have the delivered assembly instructions and other product documentation at hand when carrying out all relevant work. The personnel must consistently observe the provisions of these assembly instructions.</p> <p>All unqualified persons are prohibited from carrying out work on the components/devices or in their vicinity.</p> <p>Failure to observe the safety instructions may result in damage to computer drives and credit cards.</p>
---	---

2.4.4 Hazard posed by dangerous goods

The handling of dangerous goods (according to the German Working Material Regulation - ArbStoffV) must comply with the relevant regulations.

2.4.5 Hazard posed by pump



Warning !	
	<p>The pump poses various different hazards that can lead to injuries if instructions are not observed.</p> <p>The pump has an inlet and outlet connector, both of which allow unimpeded access to the internal rotating rotor depending on size. Reaching in with limbs poses the risk of losing fingers or hands. The pump therefore must be secured in such a way that it is not possible for persons to reach into the opening when the rotor is running.</p>
	

Figure 1 Hazards

3 Pump specifications

3.1 Technical data

Your pump is specially designed for your application. The relevant usage conditions are indicated on the delivery note and must be complied with. The limit values of your pump must not be exceeded and the pump must not be used for any other purpose.

In the absence of specific limit values, the limit values set out in the table shall apply.

3.1.1 SCN Series

* according to your usage conditions (see delivery note)

	SCN 20	SCN 25	SCN 40
Max. pressure *	10 bar	15 bar	15 bar
Max. speed *	1,000 rpm	1,000 rpm	1,000 rpm
Max. temperature *	90 °C	90 °C	90 °C
Ambient temperature	-15 °C to +40 °C	-15 °C to +40 °C	-15 °C to +40 °C

Table 1 Maximum pump limit values

3.1.2 SCN-D Series

* according to your usage conditions (see delivery note)

	SCN 25D	SCN 40D
Max. pressure *	10 bar	10 bar
Max. speed *	600 rpm	600 rpm
Max. temperature *	90 °C	90 °C
Ambient temperature	-15 °C to +40 °C	-15 °C to +40 °C

Table 2 Maximum pump limit values

3.1.3 Pressure ratios

Excess pressure can result from a blocked pressure line. Therefore, installing a pressure monitor is strongly recommended.

3.2 Intended use

The pump has been specially designed for your application. These usage conditions are indicated on the delivery note and must be complied with.

The pump is designed for the following functions only:

- For suction and conveying of precisely specified products.

3.3 Improper use

- Use of materials other than those intended for the purpose.
- Operation of the pump in a defective or damaged condition.
- Lack of protection of operating modes (e.g. keys left in).

4 Setting up the pump

4.1 Potentially explosive environment (ATEX)

The SCN series SOMA displacement pump must not be used in an explosive environment - unless it comes marked ex works with an appropriate nameplate and is thus approved.

Note Please refer to the enclosed document for the corresponding type plate.

4.2 Connector position

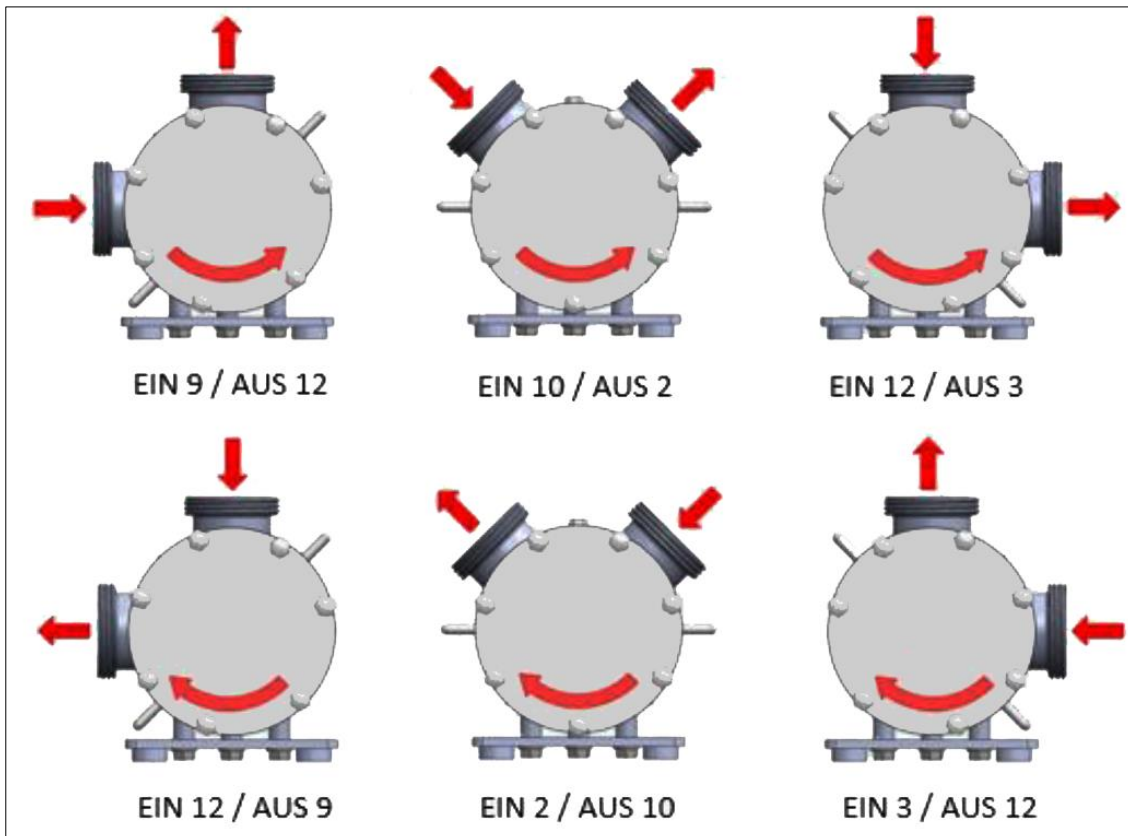

Figure 2 Connector position

4.3 Rotating connections

	<p>To move the connections on your pump to a different position, loosen and remove the two screws at the rear end of the pump housing. Rotate the pump housing in 45° increments to the desired position and re-tighten it with the two screws previously removed.</p>
---	--

Figure 3 Rotating the pump housing

4.3.1 SCN Serie

	<p>To change the position of the connections on your pump, loosen and remove the four screws at the rear end of the pump housing. Turn the pump housing in a 45° grid to the desired position and tighten it again with the four screws previously removed.</p>
---	---

Figure 4 Rotating the pump housing

4.3.2 SCN-D Serie

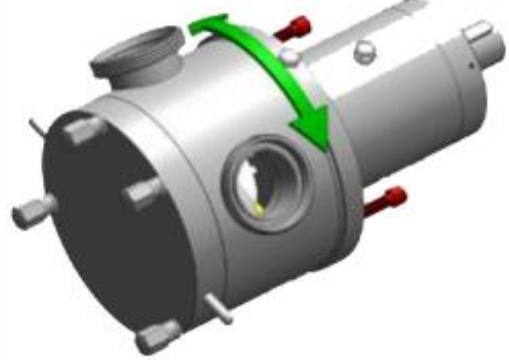

	<p>To change the position of the connections on your pump, first loosen and remove the four screws on the drive (1) and pull it off the pump. Then remove the four screws at the rear end of the pump housing (2). Turn the pump housing in a 45° grid to the desired position and tighten it again with the four screws (2) removed earlier. Then place the pump housing on the drive and fasten it with the screws (1).</p>
---	---

Figure 5 Rotating the pump housing SCN-D

4.4 Changing rotational direction

If the suction side is to be swapped for the pressure side, the pump must be opened and the rotor, scraper and guide cartridge removed as one unit. Reinstall the individual parts properly in the pump housing as one unit.

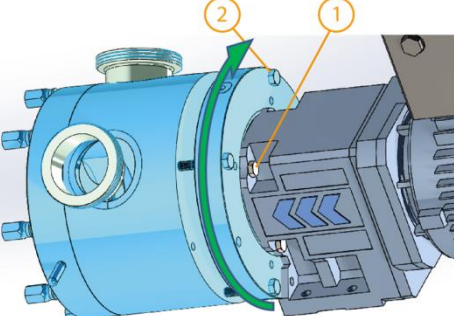
Caution !	
	<p>Rotor, scraper and guide cartridge are loosely joined together!</p> <p>Rotate the guide cartridge such that the solid back is on the suction side. The scraper positioned within the guide cartridge rests against the solid back of the guide cartridge by its long, large surface.</p>

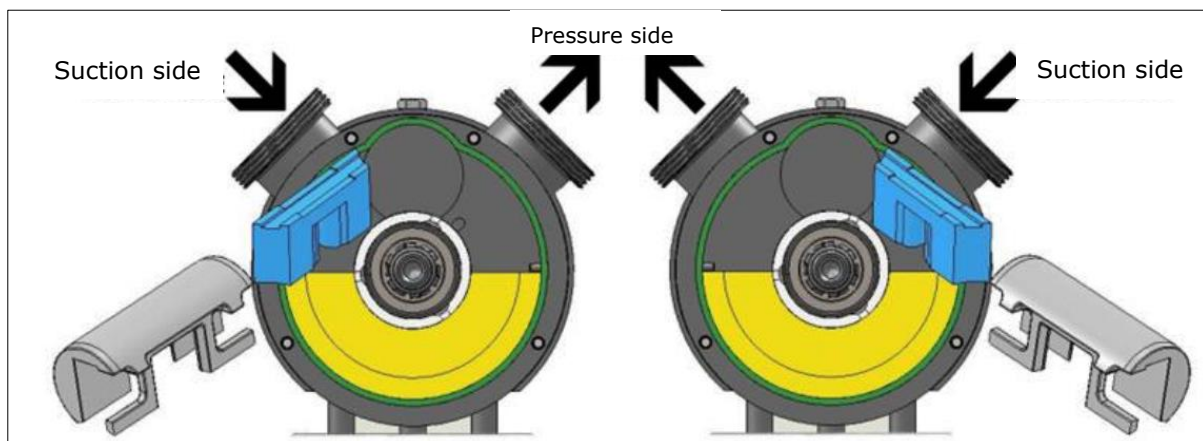



Figure 6 Changing rotational direction

4.5 Coupling to pipeline

- Residues due to work on the pipeline must be removed in order to prevent the entry of foreign objects when the pump is commissioned.
- It is recommended to integrate a compensator between the pump and the fixed-position pipeline on the pressure and suction sides to prevent the transfer of any vibration from pipeline to pump.
- A complete dry running condition can be avoided by having a pressure line face upwards (vertically), as residual fluid can flow back into the pump.
- The pipeline must be designed in such a way that an impermissible increase in pressure (*Chapter 3.1.3 "Pressure ratios"*) is not possible.
- Forces transferred to the pump by tension or expansion of the pipes must be avoided.
- The use of a frequency converter can create vibration. Vibration must be measured during commissioning and eliminated by reprogramming.

4.6 Commissioning

Caution !	
	<p>Suitable specialists must be assigned when transporting and setting up the pump.</p> <p>The pump must not be operated if:</p> <ul style="list-style-type: none"> • Ambient temperature is below: -15°C • Ambient temperature is above: +40°C



	<p>⚠ WARNING In order to avoid a dry running condition, care must be taken to refill the pump with the medium to be pumped before switching on.</p>
---	--

Figure 7 Commissioning - Dry running condition

4.7 Introduction

Note !	
	<p>If further information is required in order to perform maintenance, contact the manufacturer.</p> <p>📖 Please also note the drawings / parts lists, documents of subcontractors and the electrical documentation.</p> <p>The assembly instructions are a separate document.</p>

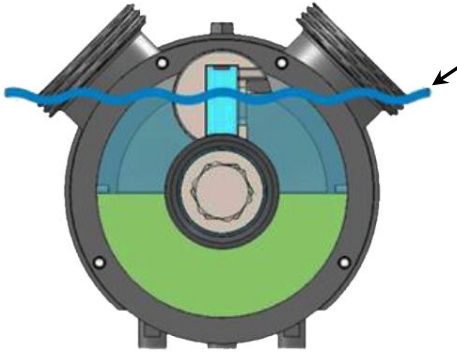
- Maintenance work may be carried out only by trained personnel who are capable of identifying hazards and assessing risks.
- Do not use aggressive cleaning agents! Do not use abrasion-promoting cleaning agents!

Warning !	
	<p>Several types of danger associated with entire machine. Inspection and maintenance work may be performed only by authorised, trained and experienced personnel.</p>

4.8 Safety instructions for specialists

Only suitable climbing aids (e.g. podiums, scaffolding or ladders) may be used to reach higher-lying parts of the plant. Components of the machine must not be climbed on.

Danger !	
	<p>Danger due to voltage! There is a risk of serious injury or death. Before working on the electrical equipment, the following safety instructions must be followed in the order indicated.</p> <ol style="list-style-type: none"> 1. Disconnect from electricity supply. 2. Secure the machine so that it cannot be turned back on unintentionally. 3. Check to ensure disconnection from electricity supply. 4. Earth and short-circuit. 5. Cover neighbouring live parts.

Note !	
	<p>Only specialists according to TRBS 1203 may be assigned to maintenance work with subsequent testing.</p>

4.9 Preparation of maintenance work

Maintenance work on this machine may require the partial disassembly or replacement of individual components. This work may be carried out only by suitable specialists in possession of the necessary aids and lifting equipment. Maintenance work may only be carried out on a machine in a secured condition, i.e. with electrical power disconnected. This involves disconnecting the line disconnect and securing it against reactivation (e.g. using a padlock). If work is to be carried out with the controller activated, the operating company must stipulate additional protective measures to ensure the safety of personnel. Protective covers may be disassembled only if the machine has been safely shut down beforehand and has been secured in this condition.

Note !	
	<p>If malfunctions occur during operation, the pump must be immediately switched off and secured against accidental or unauthorised reactivation.</p> <p>In order to preserve and utilise the service life of the machine to the fullest extent, it is necessary to perform adjustment, maintenance and inspection work according to the defined schedule. These actions must be performed only by personnel authorised by the operating company. Before any work is carried out on the machine, it must be ensured that it is switched off and secured against inadvertent activation. It is recommended that the machine be additionally marked by a warning label.</p>

4.10 Oil change and fill quantity, SCN Series

The oil level must be checked before the pump is commissioned on each occasion. An oil sight glass showing the oil level is located on the side of the bearing housing (item 11) – the oil level should be in the middle of the sight glass. If the oil level is lower than this, suitable oil must be added - this is performed by unscrewing the bleeder valve to reveal an opening for topping up the oil. Initial filling is performed with oil 4 UH 1-220 N (suitable for the food and pharmaceutical industry).

In the case of an oil change, old oil should be sent to be reprocessed.

Pump size	SCN 20	SCN 25	SCN 40
Filling quantity	0.1 litres	0.2 litres	0.4 litres

Table 3 Oil change - filling quantities

4.11 Changing spare parts

In the case of repair work on the pump, it must be ensured that the machine is completely disconnected from the power supply. When removing and installing spare parts, it must be noted that some components of the pump can be heavy or breakable.

In the case of spare parts orders, the serial number should be provided to avoid any delay or inconsistency in identifying parts.

4.12 Servicing of bearings

We recommend that the pump be sent to the plant for inspection after **5,000 operating hours** or **after 6 months**. To avoid consequential damage caused by worn and defective bearings, it is recommended to replace these with new bearings every 10,000 operating hours.

Note !	
	<p>The service life of the bearings can be achieved only if the front bearing is installed correctly T04SXX-0960-55 - T04SXX-0960-62 front bearing.</p>

4.13 Adjustment dimension "X"

4.13.1 SCN Series

When changing bearings, the axial adjustment dimension must be subsequently checked and, if necessary, adjusted. For this purpose, use the available spacer rings, which come in different material thicknesses (0.1 / 0.2 mm).

Measure the current dimension "X" at the repaired pump.

In the case of a face seal, the static ring holder (item 9) must not be installed. Make sure that the dynamic ring holder (item 1) required for measurement does not contain an O-ring (item 12) and is pushed over the shaft as far as it will go.

In the case of a shaft ring seal, only the sealing sleeve (item 9) is required for measurement. This must also be pushed over the shaft as far as it will go.

See table below

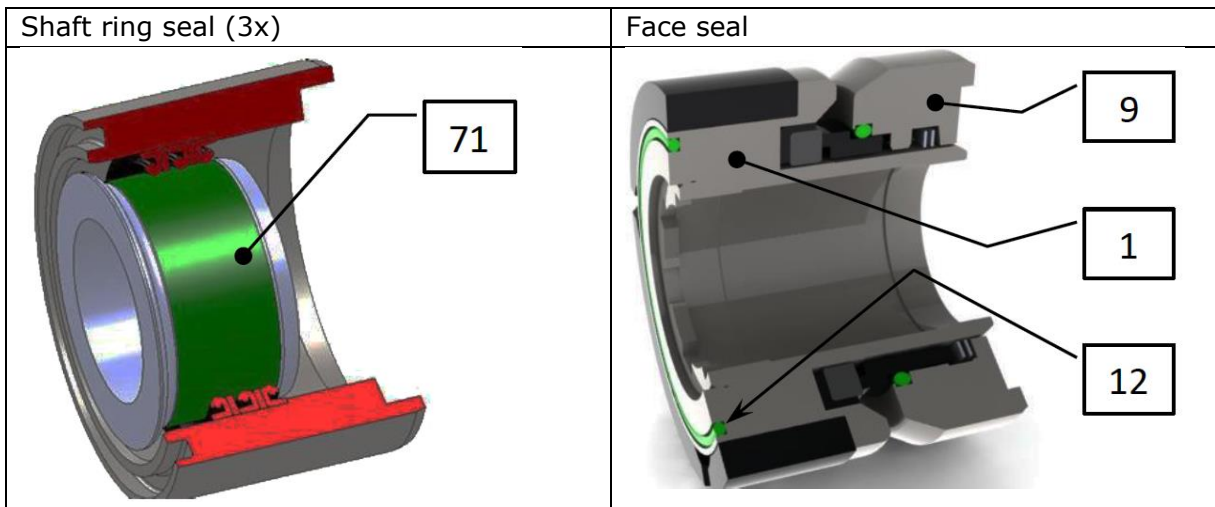

Figure 8 Sealing system for adjustment dimension "X"

The figure below shows where to measure.

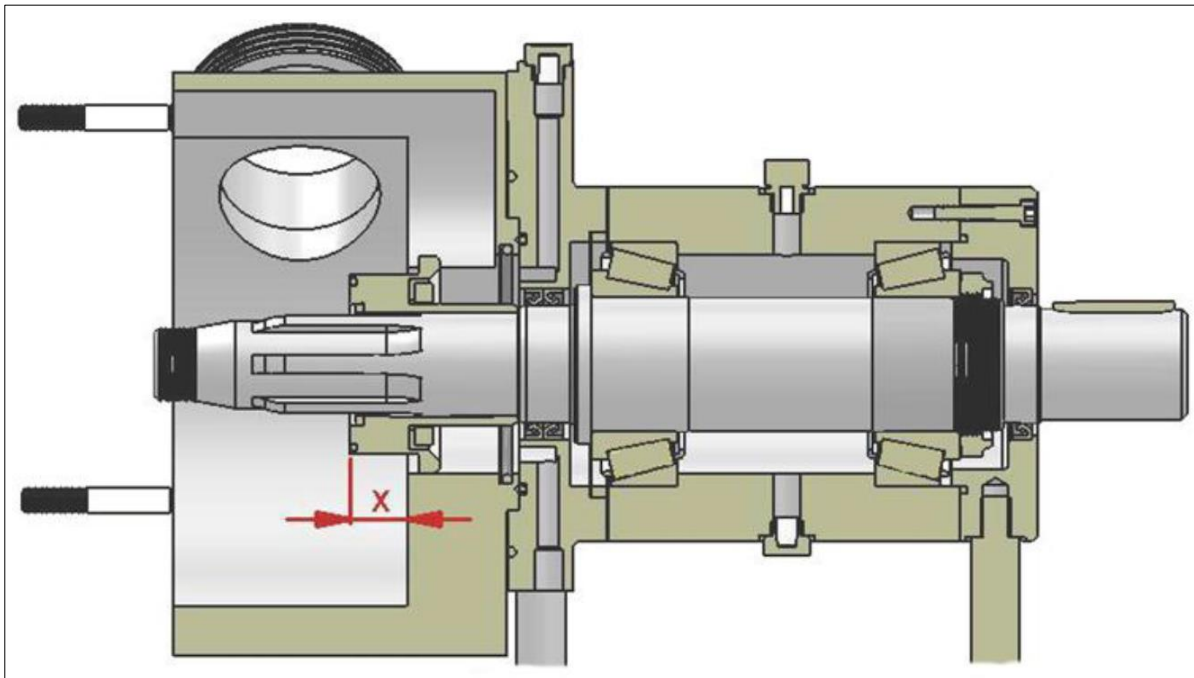

Figure 9 Adjustment dimension "X"

Pump size		SCN 20	SCN 25	SCN 40
Adjustment dimension "X"		17,5 mm +0,1	23 mm +0,1	15 mm +0,1

Table 4 Adjustment dimension

The measured adjustment dimension "X" is compared to the specified adjustment dimension in Table 3. The calculated difference determines the number and material thickness of the spacer discs to be used.

Calculation example on an SCN25:

Specified adjustment dimension: 23 +0.1 mm

Measured adjustment dimension: 22.8 mm

Difference: 0.2 mm

Spacer disc to use: 0.2 mm

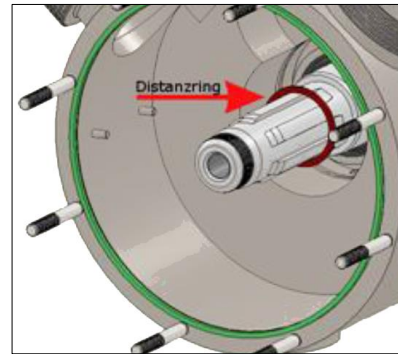

Figure 10 Spacer ring installation

Spacer ring sets		
Pump type	Article no.	Dimensions
SCN20	T04S20-1401-10	0,1/0,15/0,2/0,3
SCN25	T04S25-1401-10	0,1/0,15/0,2/0,3
SCN40	T04S40-1401-10	0,1/0,15/0,2/0,3

Table 5 Spacer ring sets

4.13.2 SCN-D Serie

When changing bearings, the axial adjustment dimension must be subsequently checked and, if necessary, adjusted. For this purpose, use the available spacer rings, which come in different material thicknesses (0.1 / 0.15 / 0.2 / 0.3 mm).

Measure the current dimension "X" at the repaired pump.

In the case of a face seal, the static ring holder (item 9) must not be installed. Make sure that the dynamic ring holder (item 1) required for measurement does not contain an O-ring (item 12) and is pushed over the shaft as far as it will go.

In the case of a shaft ring seal, only the sealing sleeve (item 71) is required for measurement. This must also be pushed over the shaft as far as it will go.

See table below

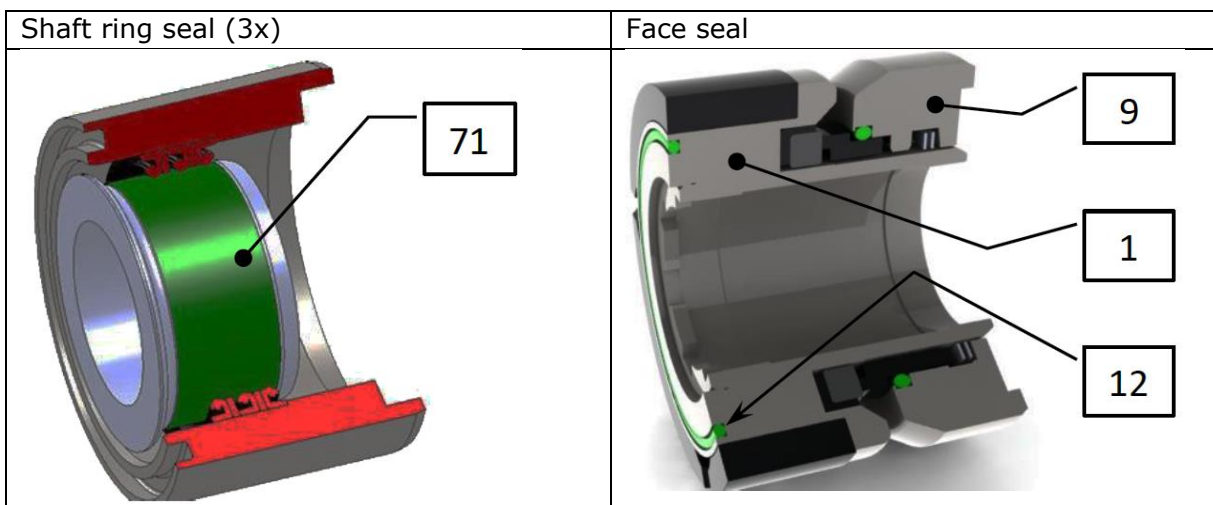

Figure 11 Sealing system for adjustment dimension "X"

The figure below shows where to measure.

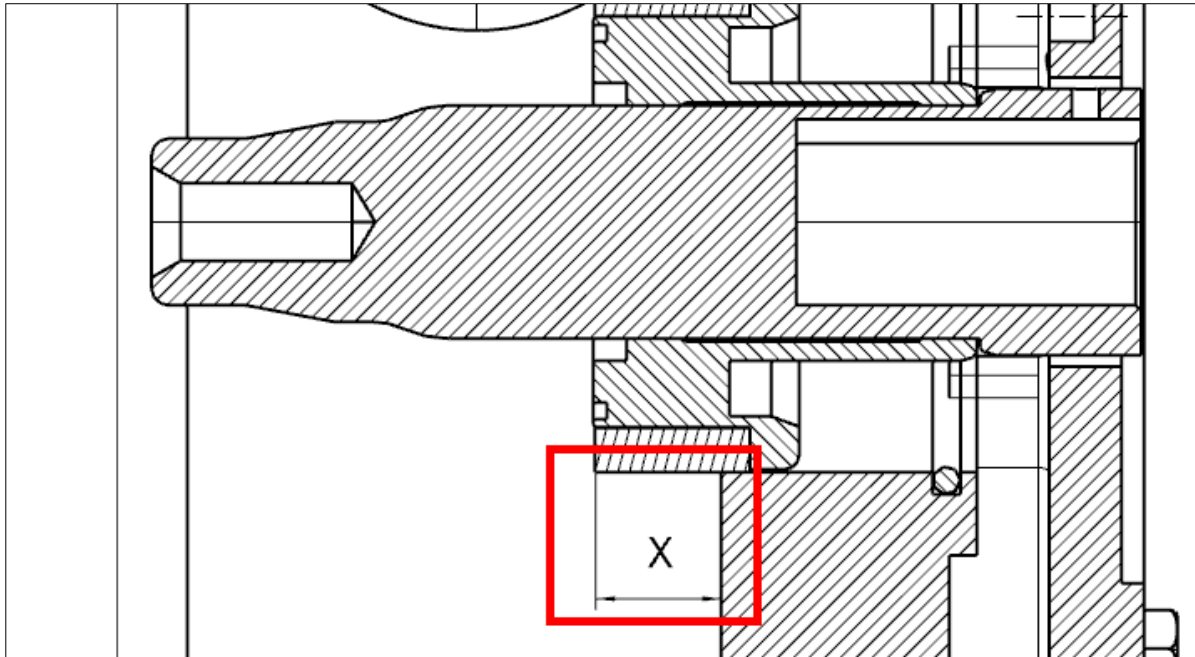

Figure 12 Adjustment dimension "X"

Pump size	SCN 25D	SCN 40D
Adjustment dimension "X"	23 mm +0,1	15 mm +0,1

Table 6 Adjustment dimension

The measured adjustment dimension "X" is compared to the specified adjustment dimension in Table 3. The calculated difference determines the number and material thickness of the spacer discs to be used.

Calculation example on an SCN25D:

Specified adjustment dimension: 23 +0.1 mm

Measured adjustment dimension: 22.8 mm

Difference: 0.2 mm

Spacer disc to use: 0.2 mm

Spacer ring sets		
Pump type	Article no.	Dimensions
SCN25D	T04S25-1401-10	0,1/0,15/0,2/0,3
SCN40D	T04S40-1401-10	0,1/0,15/0,2/0,3

Table 7 Spacer ring sets

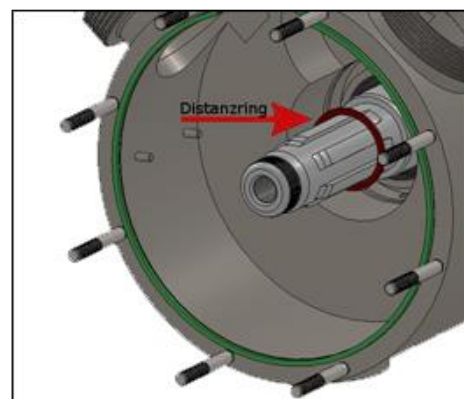

Figure 8 Spacer ring installation

4.14 Error description

4.14.1 SCN Serie

Problem	Possible cause	Rectification
Unilateral wear of the rotor.	Incorrect torque when mounting rotor.	Mount locking nut on carrier shaft to specified torque and secure with locking screw → See Chapter 8.
	Changes to adjustment dimension X, by replacing parts.	Check adjustment dimension X and, if necessary, correct: → See <i>Chapter 5.7</i> .
Front bearing seized on rotor.	Missing or worn O-ring in front bearing.	Mounting an O-ring or replacing the O-ring.
	Front bearing assembly fault.	Inspection of the front bearing for damage and proper assembly.
Rotor seized on stator.	Too little torque when tightening the rotor.	Mount the locking nut to the specified torque and secure with locking screw → See Chapter 8.
	Excessive thermal expansion due to high temperatures.	Appropriate tolerance with respect to plastic parts.
The bearing housing contains medium to be pumped.	Excessive flushing pressure.	Flushing must be without pressure (a new pressure reducer must be fitted at a maximum of 0.1 bar) → See Chapter 7.
	The drainage holes in the bearing block are clogged.	Clear drainage holes of contamination, check the O-rings and shaft sealing rings in the pump and in the bearing block for damage and, if necessary, replace.
Outlet of medium to be pumped from the openings of the bearing housing.	Defective or worn pump sealing system.	Check the sealing system and, if applicable, replace. Cleaning of flushing channels in the bearing housing.
Rinsing medium is escaping between the housing and the bearing block.	Missing or damaged O-ring in the bearing block.	Check the O-Ring and replace it if necessary.
The pump starts to vibrate.	Engine speed too high.	Choose a slower speed.
Defective CIP cleaning.	Failure to comply with cleaning regulations.	The pressure on the pressure side must be 3 to 4 bar

Problem	Possible cause	Rectification
		higher than on the suction side → See Chapter 7.4.
Pump starts with odorous emissions and smoke.	The pump runs without liquid (dry running condition).	Stop the pump. Dismantling of pump, checking of pump for damage.
Blocking of pump.	Foreign objects in the pump.	Dismantle the pump and remove any foreign objects, clean, check pump for damage.
	Interrupted power supply.	Inspection of electrical equipment and fuses.
	Drive defective.	Dismantle the pump's coupling and verify that the pump can be turned by hand.
High degree of wear after a few hours of operation.	Solid matter in the medium to be pumped.	Regular replacement of wear parts, inspection of material components.
	Abrasive effect of the medium to be pumped.	Test the medium to be pumped for abrasive ingredients, reduce the speed or check the pump size.

4.14.2 SCN-D Serie

Problem	Possible cause	Rectification
Noise generation in the pump.	Pump unit makes a noise.	Contact SOMA.
	Cavitation.	Reduce speed, shorten suction line, use larger diameter of suction line.
	Impact noise from the pump.	Check the slide/scrapper for wear and, if necessary, replace.
	Drive makes a noise.	Contact SOMA.
Pump leaking.	O-ring seal leaking.	Replace O-rings.
	Sealing system leaking.	Überprüfung von Gleitringdichtung oder Radialwellendichtring ggf. austauschen.
Faulty suction of the pump.	Too long suction line.	Optimisation of suction line.
	Incorrect installation of guide cartridge and slide/scrapper.	Inspection of guide cartridge and slide/scrapper installation.
	Screw connection has loosened.	Inspection of screw connection.

Problem	Possible cause	Rectification
	Incorrect rotation direction.	Check of rotation direction → See Chapter 4.4.
	Too small pipe cross section.	Optimisation of suction line.
	Leaking shaft seal.	Inspection of seals for visual signs of damage.
	Appearance of wear in the pump.	Replacement of wear parts.
	Engine speed not correct.	Check and adjustment of speed.
	Pump without liquid.	Filling of pump with liquid → <i>See Chapter 4.6.</i>
Front housing of pump leaking.	Front housing seal not fitted or incorrectly fitted.	Fit O-rings properly or replace.
	Damage to front housing seal.	Replacement of O-ring.
The pump starts to vibrate.	Engine speed too high.	Choose a slower speed.
Front bearing seized on rotor.	Missing or worn O-ring in front bearing.	Mounting an O-ring or replacing the O-ring.
Pump does not pump.	Mix-up of pressure and suction line.	Inspection of pipelines.
	Incorrect rotation direction.	Change rotation direction.
	Engine speed incorrect.	Check speed based on performance charts.
	Pump worn.	Replacement of wear parts.
Unilateral wear of the rotor.	Incorrect mounting of guide cartridge and scrapers.	Check installation direction → See Chapter 4.2.
	Incorrect torque when mounting rotor.	Mount locking nut on carrier shaft to specified torque and secure with locking screw → See Chapter 8.
Front bearing seized on rotor.	Changes to adjustment dimension X, by replacing parts.	Check adjustment dimension X and, if necessary, correct: → See Chapter 5.6.
	Missing or worn O-ring in front bearing.	Mounting an O-ring or replacing the O-ring.
Rotor seized on stator.	Front bearing assembly fault.	Inspection of the front bearing for damage and proper assembly.
	Too little torque when tightening the rotor.	Mount the locking nut to the specified torque and secure with locking screw → See Chapter 8.
	Excessive thermal expansion due to high temperatures.	Appropriate tolerance with respect to plastic parts.

Problem	Possible cause	Rectification
The bearing housing contains medium to be pumped.	Excessive flushing pressure.	Flushing must be without pressure (a new pressure reducer must be fitted at a maximum of 0.1 bar) → See Chapter 7.
Outlet of medium to be pumped from the openings of the bearing housing.	Defective or worn pump sealing system.	Check the sealing system and, if applicable, replace. Cleaning of flushing channels in the bearing housing.
The pump starts to vibrate.	Engine speed too high.	Choose a slower speed.
Defective CIP cleaning.	Failure to comply with cleaning regulations.	The pressure on the pressure side must be 3 to 4 bar higher than on the suction side → See Chapter 7.4.
Pump starts with odorous emissions and smoke.	The pump runs without liquid (dry running condition).	Stop the pump. Dismantling of pump, checking of pump for damage.
Blocking of pump.	Foreign objects in the pump.	Dismantle the pump and remove any foreign objects, clean, check pump for damage.
	Interrupted power supply.	Inspection of electrical equipment and fuses.
	Drive defective.	Dismantle the pump's coupling and verify that the pump can be turned by hand.
High degree of wear after a few hours of operation.	Solid matter in the medium to be pumped.	Regular replacement of wear parts, inspection of material components.
	Abrasive effect of the medium to be pumped.	Test the medium to be pumped for abrasive ingredients, reduce the speed or check the pump size.

5 Decommissioning, dismantling and disposal

5.1 Decommissioning, dismantling

⚠ WARNING

Only suitable specialists may be assigned to dismantling the plant or individual components.

Appropriate tools, such as climbing aids, lifting equipment or implements, must be provided.

If the operating company does not have the necessary means to safely dismantle the equipment, the operating company must appoint appropriate specialists.

In the case of short-term or long-term shutdown of the pump, care must be taken to ensure that:

- The main switch is deactivated.
- Product residues are completely removed.
- The pump is cleaned (depending on the medium pumped).
- Connections are masked.
- Rinsing fluids are drained.

5.2 Disposal

Disposal of the plant or of individual machines may be performed only by a company that can demonstrate specific knowledge and experience in the area of waste removal and disposal. Disposal of operating materials and lubricants is precisely regulated by the Environmental Protection Act and its ordinances.

6 Flushing and cleaning

6.1 Flushing

Note !	
	Contamination and foreign objects in the rinsing medium must be avoided.

The pump is equipped as standard with flushing channels to which a tube connector can be screwed. The main seal may be flushed behind at a maximum of 0.5 bar of pressure to rinse away penetrating pumped medium or to prevent its contact with the atmosphere.

6.1.1 SCN Series

Pump size	SCN 20	SCN 25	SCN 40
Thread size	G 1/8"	G 1/4"	G 1/4"

Table 8 Connection for flushing

6.1.2 SCN-D Series

Pump size	SCN 25D	SCN 40D
Thread size	G 1/4"	G 1/4"

Table 9 Connection for flushing

6.2 Cleaning in own circuit

	<p>The pump can clean itself in the circuit by its own rotation. Note the following:</p> <ol style="list-style-type: none"> 1. Set maximum speed 2. Set counter pressure from 3 to 4 bar <p>Depending on the medium pumped, the product area in the pump may not have been completely cleaned. In this case, the pump must be opened and the interior and individual parts cleaned by hand.</p>
---	---

Figure 13 Cleaning in own circuit

6.3 Cleaning by hand

Before cleaning the pump, it must be ensured that the pump has been switched off and disconnected from the power supply by an instructed person. The pump can now be opened and all internal parts can be removed from the pump housing. In order to avoid damage to plastic parts and injury to persons, care must be taken during cleaning tasks to ensure proper handling of cleaning agents and solvents used.

6.4 Cleaning in the CIP circuit

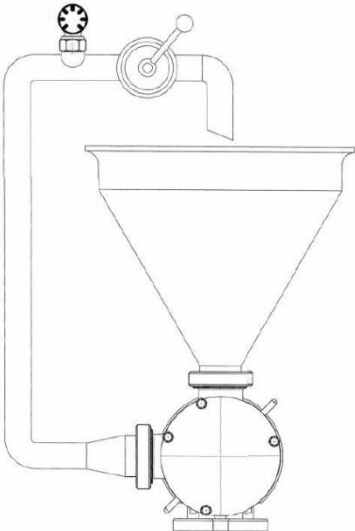
SCN series pumps are fully suitable for CIP cleaning. Note the following:

	<ol style="list-style-type: none"> 1. Intermittent flushing For initial rough cleaning, open the throttle valve and run the pump at maximum permissible speed (see Chapter 3.1 Technical data) 2. Flushing The counter pressure on the pressure side must be at least 3 bar higher than the pressure on the suction side. Open the check valve to ensure the cleaning of downstream devices.
---	--

Figure 13 Cleaning in the CIP circuit

6.5 Sterilisation

The pumps of the SCN and SCN-D series can generally be sterilised at a maximum of 110°C when not in use. If higher temperatures are required, the manufacturer or the supplier of the pumps must be consulted.

6.5.1 SCN Series

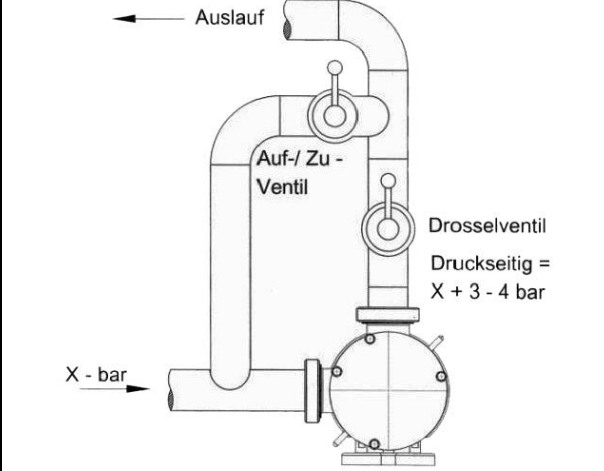
Item	Thread			Torque			Quantity		
	SCN 20	SCN 25	SCN 40	SCN 20	SCN 25	SCN 40	SCN 20	SCN 25	SCN 40
08	M8	M10	M12	25 Nm	50 Nm	35 Nm	4 pieces	4 pieces	4 pieces
26	R 1/8"	R 1/4"	R 1/4"	10 Nm	25 Nm	25 Nm	1 piece	1 piece	1 piece
29	M8	M10	M12	35 Nm	40 Nm	40 Nm	4 pieces	4 pieces	4 pieces
38	Locking nut			75 Nm	110 Nm	125 Nm	1 piece	1 piece	1 piece
40	Locking screw (Left-hand thread)			65 Nm	95 Nm	105 Nm	1 pieces	1 pieces	1 pieces
01	Cap nut			35 Nm	45 Nm	45 Nm	3 pieces	4 pieces	8 pieces

Table 10 Torques (screws)

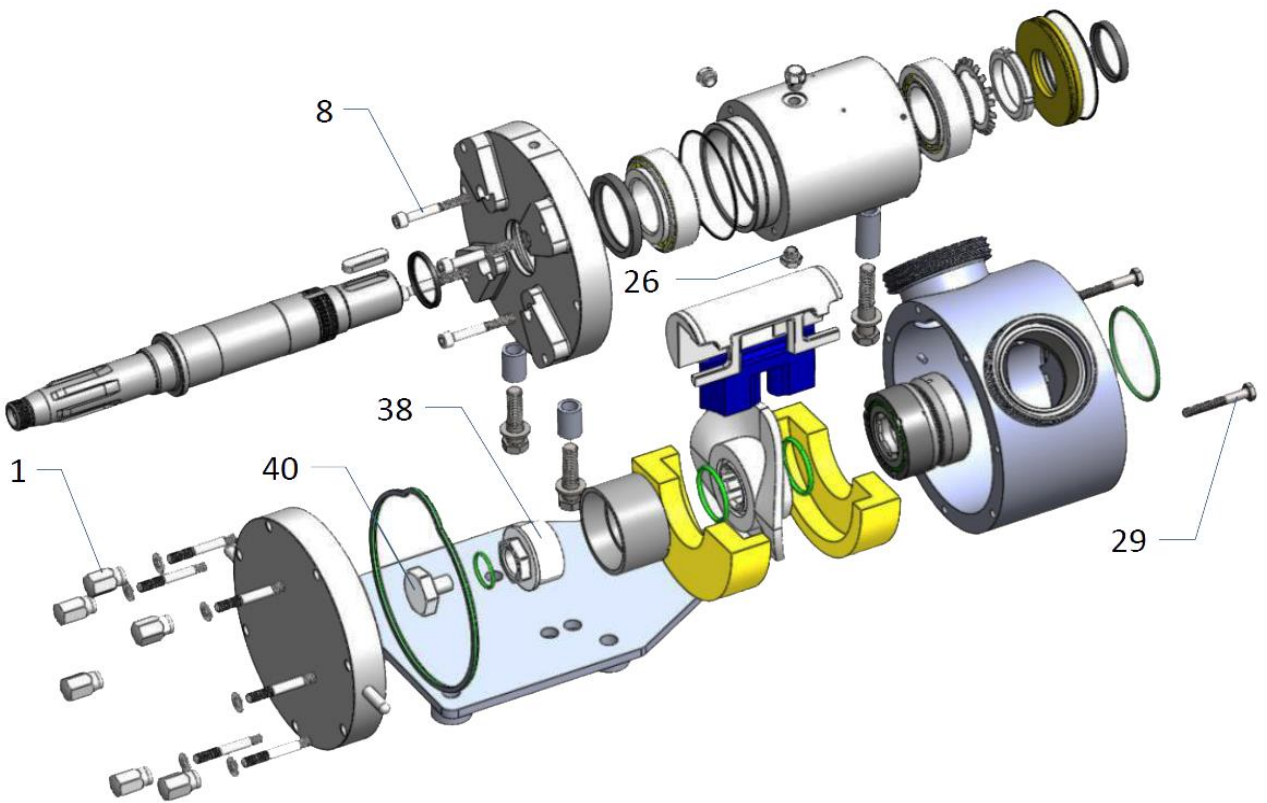

6.5.2 SCN-D Series

Item	Thread		Torque		Quantity	
	SCN 25D	SCN 40D	SCN 25D	SCN 40D	SCN 25D	SCN 40D
08	M10	M12	50 Nm	35 Nm	4 pieces	4 pieces
29	M10	M12	40 Nm	40 Nm	4 pieces	4 pieces
38	Locking nut		110 Nm	125 Nm	1 piece	1 piece
40	Locking screw (Left-hand thread)		95 Nm	105 Nm	1 piece	1 piece
01	Cap nut		45 Nm	45 Nm	4 pieces	8 pieces

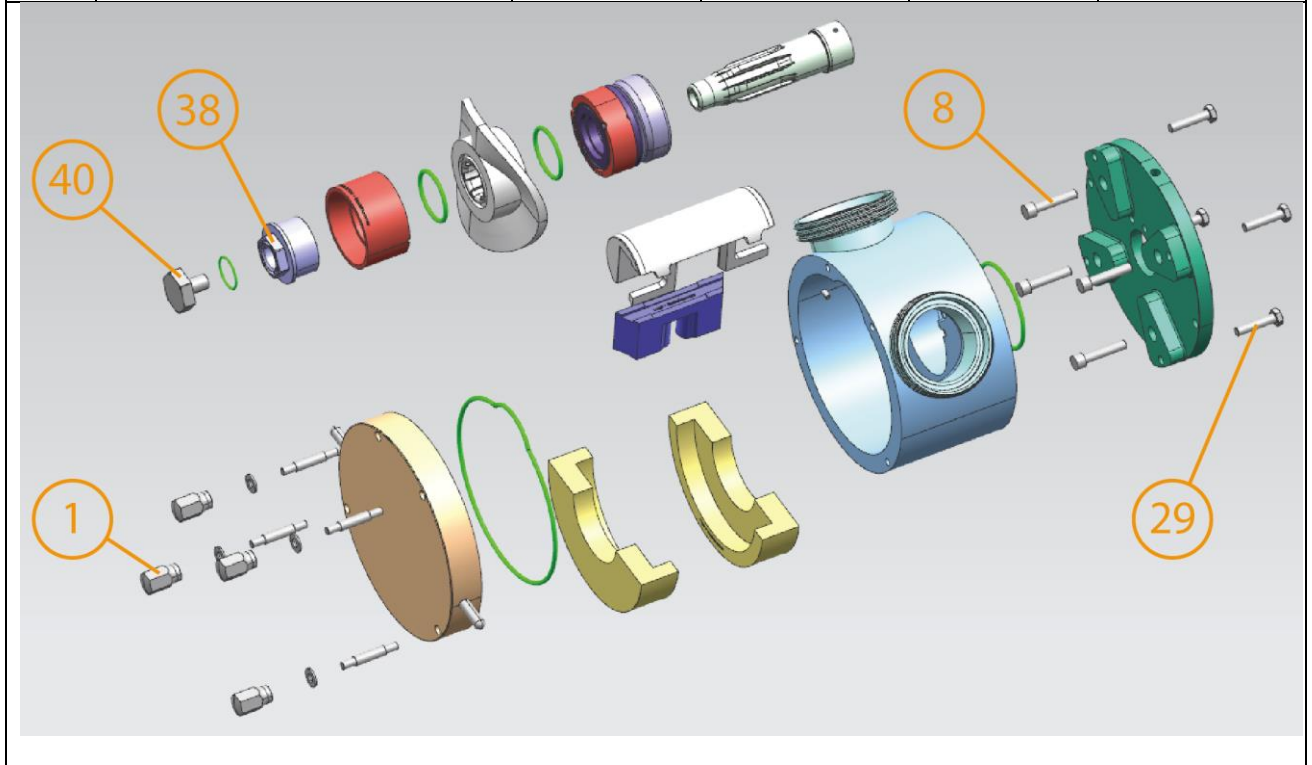

7 Assembly - disassembly - transport





7.1.1 Delivery

For the exact scope of delivery, see the order papers. Compare these with the delivery note. The dimensions and weights are listed in the delivery papers.

7.1.2 Checking the delivery for completeness

Check the entire consignment on the basis of the accompanying delivery note to ensure that it is complete. Please observe our terms of sale and delivery.



7.1.3 Safety instructions

Danger !	
   	<p>Risk of personal injury and damage to property!</p> <p>To prevent damage and life-threatening injuries during transport, please note the following:</p> <ul style="list-style-type: none"> Use appropriate lifting aids and fastening elements. Observe the pump weight specifications (weights and dimensions). Only use lifting aids with a sufficient load-bearing capacity. Lifting aids are only allowed to be used by authorised personnel. Observe accident prevention regulations. Cables and lines must be laid with the required radius to prevent damage to them and to eliminate a tripping hazard. Do not stand under or near moved loads. Moved loads can tip over, fall down, and trap people. Before the machine is lifted, all persons must leave the hazard area of the lifting aid.

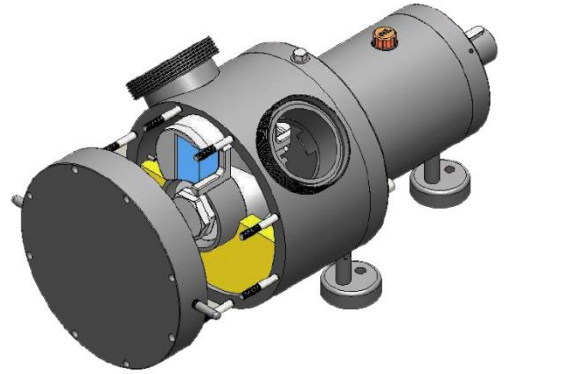
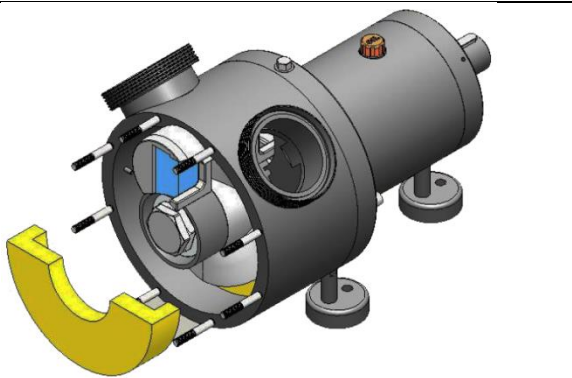
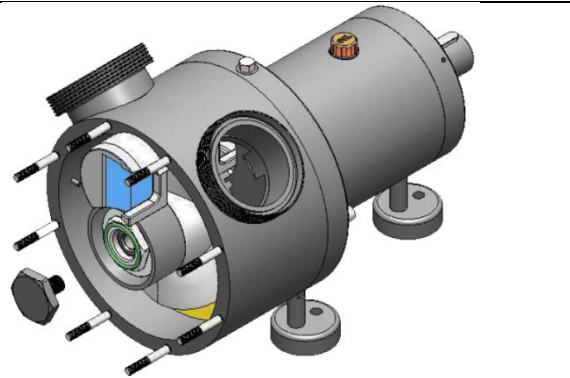
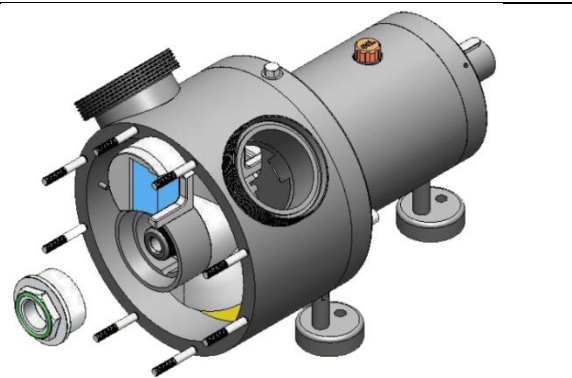
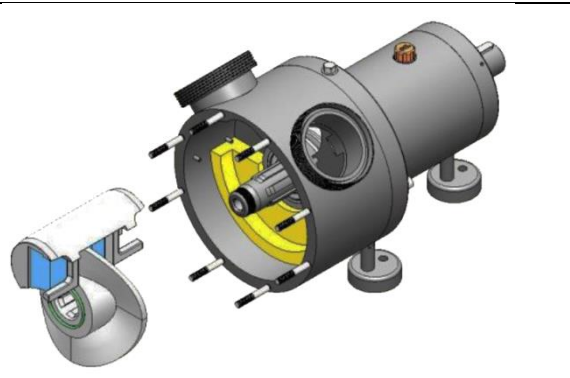

7.2 Dismantling the pump head

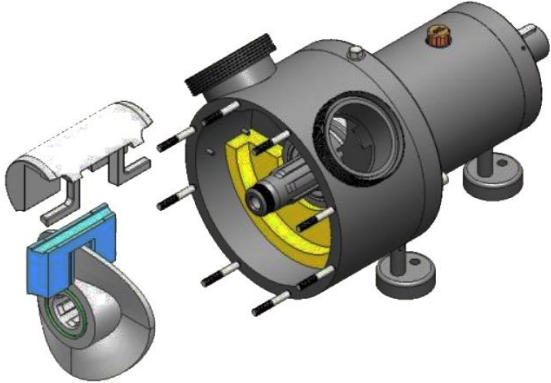
7.2.1 Pump head of the SCN Series

	
<p>1. Loosen and remove the cap nuts and washers.</p>	<p>2. Remove the front cover.</p>
	
<p>3. Remove the front stator.</p>	<p>4. Loosen and remove the locking screw (left-turning).</p>
	
<p>5. Loosen and remove the locking nut.</p>	<p>6. Carefully remove the rotor / guide cartridge / scraper as a unit ⚠WARNING Risk of trapping fingers and hands!</p>

	
<p>7. Dismantle unit.</p>	<p>8. Remove rear stator.</p>

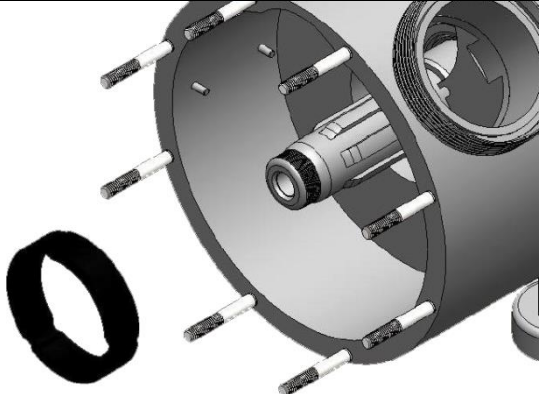
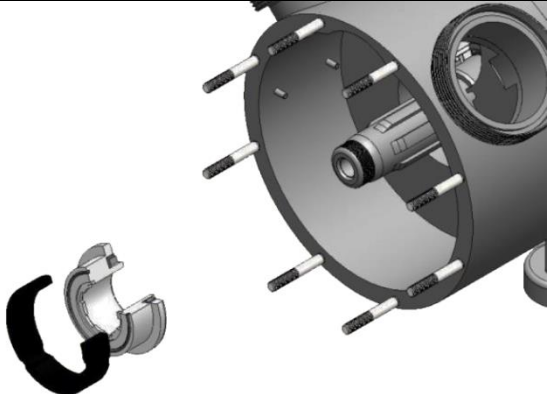
7.2.2 Removal of sealing system SCN Series

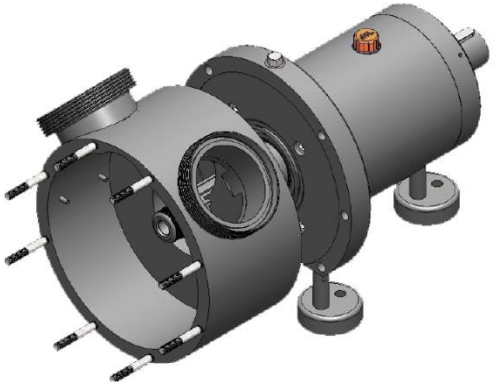
	
<p>1. Remove the supporting ring.</p>	<p>2. Pull the dynamic ring holder (stainless steel) with pressed-in surface dynamically over the shaft, remove.</p>
	
<p>3. Loosen and remove the cylinder bolts (2 pcs). ⚠ WARNING The pump housing is no longer protected against falling down!!!</p>	<p>4. The pump housing can now be removed. Rotating allows you to select a different connector position.</p>

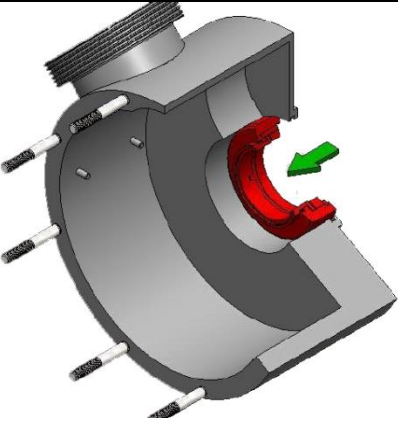
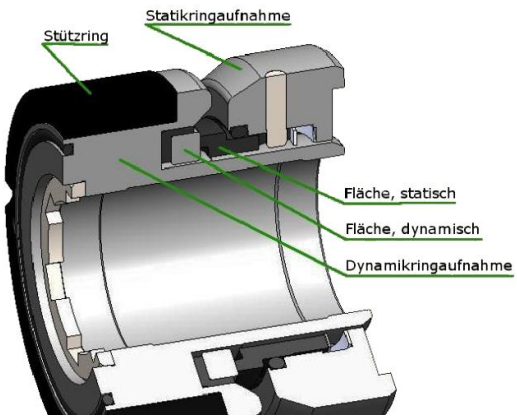
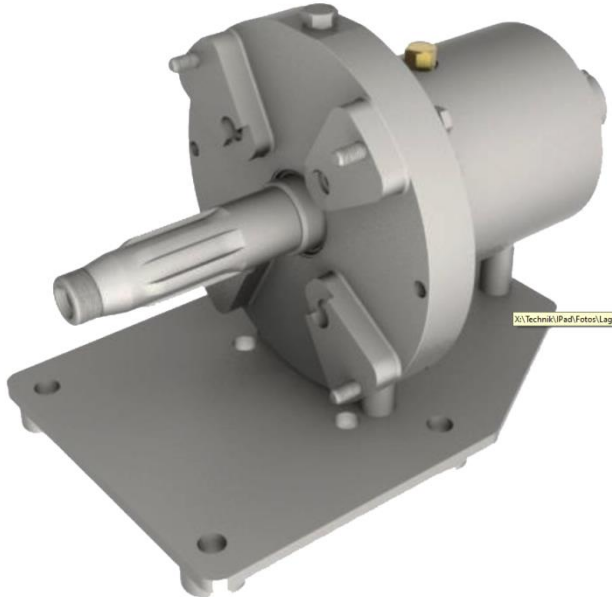
	
<p>5. The static ring package of the face seal must be pressed out of the pump housing from behind, in the direction of the arrow.</p>	
	
<p>We recommend having the storage unit reconditioned or repaired by us in-house when replacing the bearings and/or shaft. To do so, send the pump to the delivery address on the right after discussing this with us.</p>	<p>Delivery address: SOMA Pumps GmbH Seestraße 1 D-74232 Abstatt Tel.: +49 (0) 7062 91 58 83-33 Email: info@soma-pumps.de</p>

7.2.3 Dismantling the pump head of the SCN-D Series

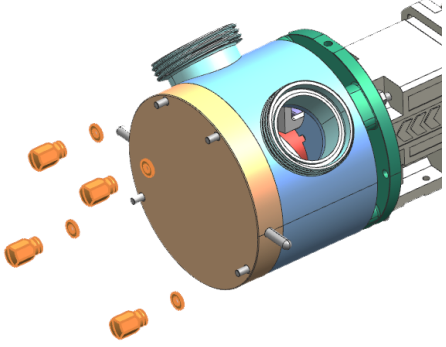
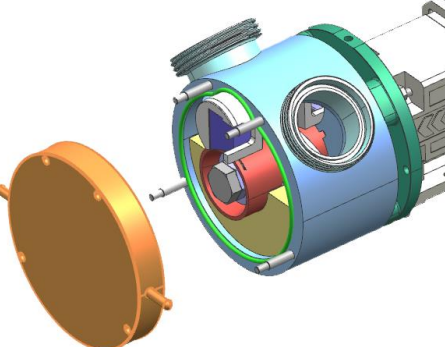
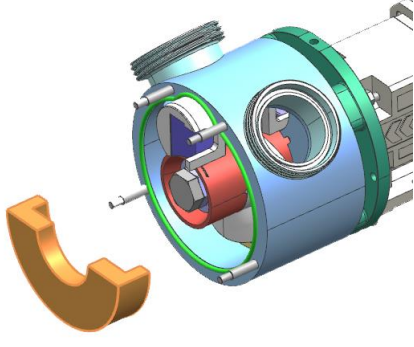
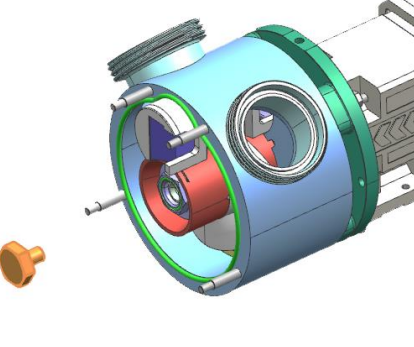
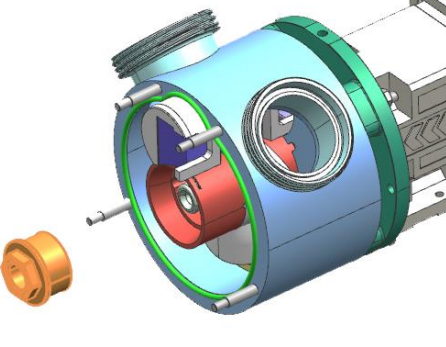
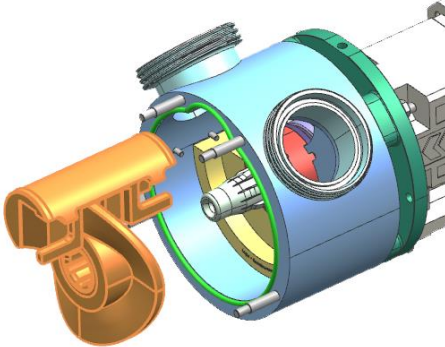
	
<p>Loosen and remove the cap nuts and washers.</p>	<p>Remove the front cover.</p>
	
<p>Remove the front stator.</p>	<p>Loosen and remove the locking screw (left-turning).</p>
	
<p>Loosen and remove the locking nut.</p>	<p>Carefully remove the rotor / guide cartridge / scraper as a unit ⚠WARNING Risk of trapping fingers and hands!</p>

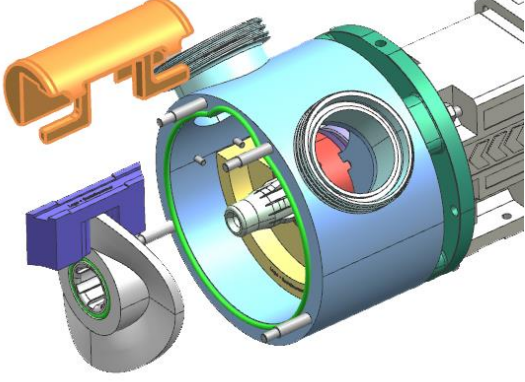
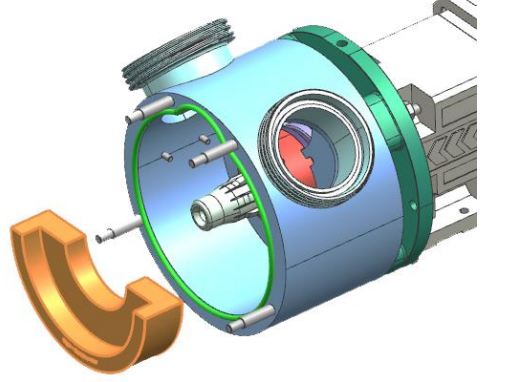
	
<p>Dismantle unit.</p>	<p>Remove rear stator.</p>

7.2.4 Removal of sealing system SCN-D Series

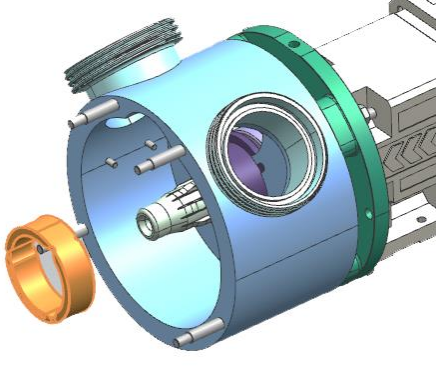
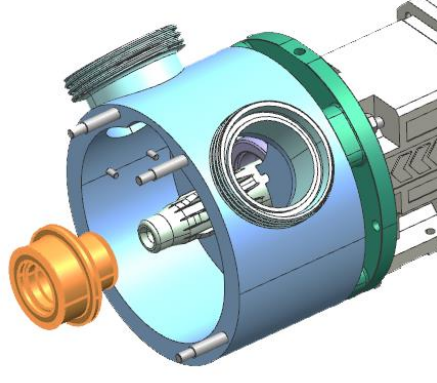
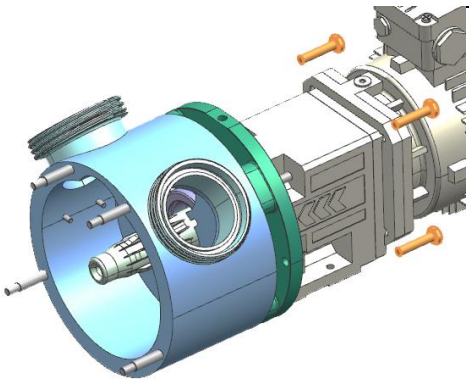
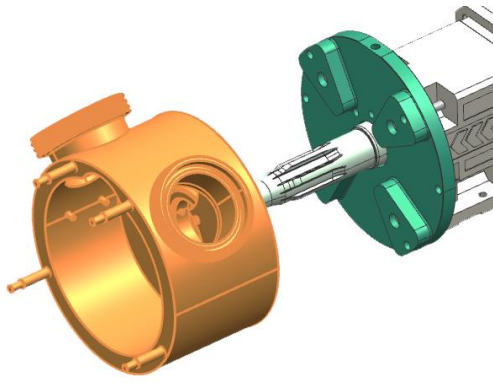
	
<p>Remove the supporting ring.</p>	<p>Pull the dynamic ring holder (stainless steel) with pressed-in surface dynamically over the shaft and remove.</p>
	
<p>Loosen and remove the cylinder bolts (4 pcs). ⚠ WARNING The pump housing is no longer protected against falling down!!!</p>	<p>The pump housing can now be removed. Rotating allows you to select a different connector position.</p>

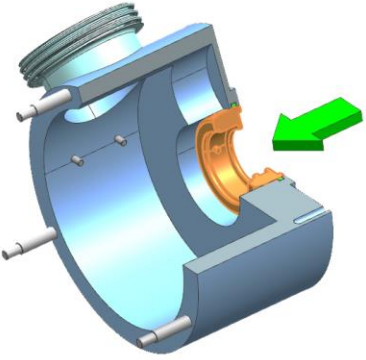
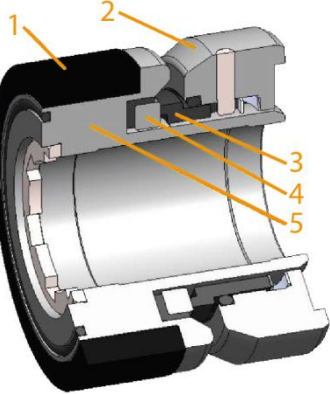
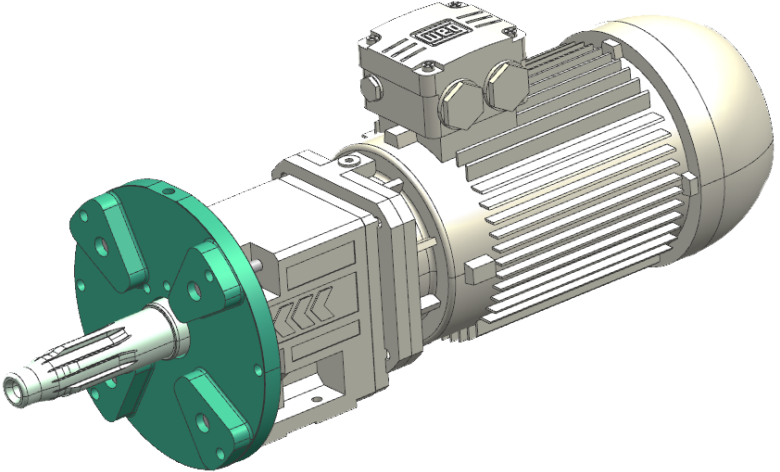
	
<p>The static ring package of the face seal must be pressed out of the pump housing from behind, in the direction of the arrow.</p>	<p>1 = Supporting ring 2 = Static ring holder 3 = Surface, static 4 = Surface, dynamic 5 = Dynamic ring holder</p>
	
<p>We recommend having the storage unit reconditioned or repaired by us in-house when replacing the bearings and/or shaft. To do so, send the pump to the delivery address on the right after discussing this with us.</p>	<p>Delivery address: SOMA Pumps GmbH Seestraße 1 D-74232 Abstatt Tel.: +49 (0) 7062 91 58 83-33 Email: info@soma-pumps.de</p>

8 Sectional drawing with parts list

8.1 SCN20 with parts list

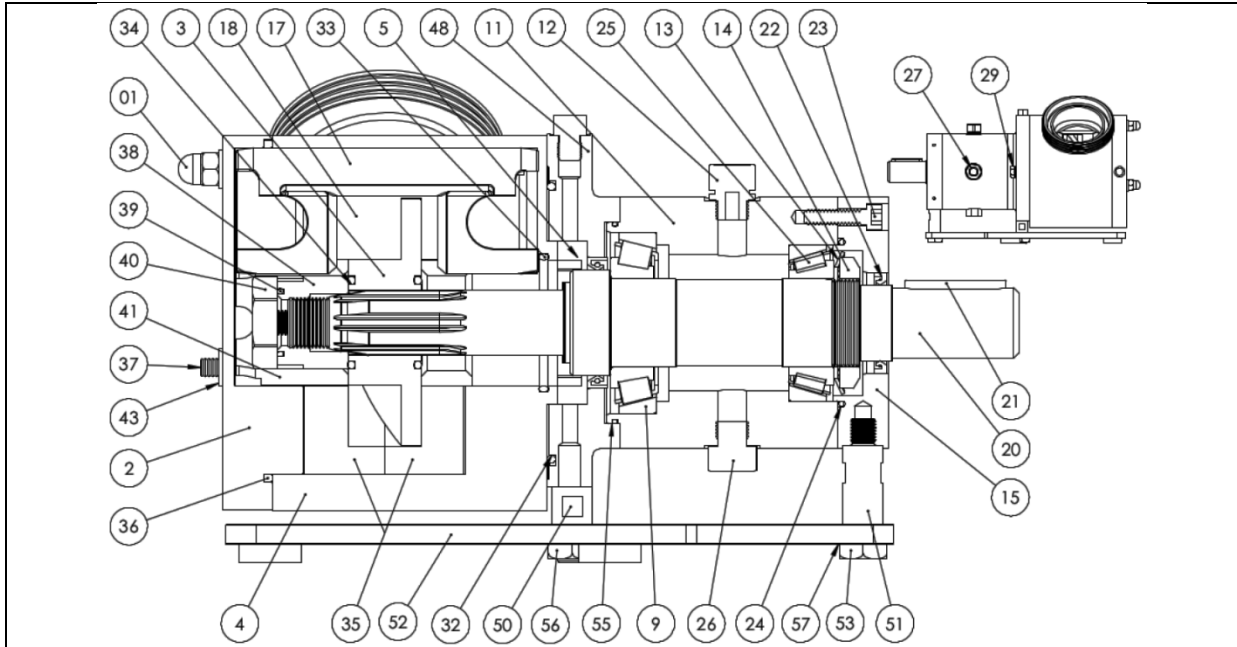

Item	Product number	Units	Description	Item	Product number	Units	Description
1	T04S20-1600-12	3	Cap nut	26	T04S20-3700-25	1	Oil drain screw
2	T04S20-0200-10	1	Front cover	27	T04S20-3800-51	1	Oil sight glass
3	T04S20-0100-10	1	Rotor	29	T04S20-1900-12	2	Hexagon screw
4	T04S20-0300-10	1	Pump housing	32	T04S20-1753-80	1	O-ring, intermediate flange
5	T04S20-2300-82	1	Radial shaft sealing ring	33	T04S20-1750-84	1	O-ring, pump housing
8	T04S20-2200-12	3	Cylinder bolt	34	T04S20-1751-84	2	O-ring, rotor
9	T04S20-2400-25	1	Tapered roller bearing	35	T04S20-1200-50	2	Stator
10	T04S20-1401-30	2	Spacer disc	36	T04S20-1701-84	1	O-ring, front cover
11	T04S20-1400-12	1	Bearing housing	37	T04S20-1800-12	3	Stud screw
12	T04S20-6000-51	1	Bleeder valve	38	T04S20-0800-10	1	Locking nut
13	T04S20-2700-25	1	Safety plate	39	T04S20-1752-84	1	O-ring, locking nut
14	T04S20-2800-25	1	Shaft nut	40	T04S20-1100-10	1	Locking screw
15	T04S20-1500-12	1	Cover	41	T04S20-0960-55	1	Front bearing
17	T04S20-0700-10	1	Guide cartridge	43	T04S20-1601-12	3	Washer
18	T04S20-0400-49	1	Scraper	48	T04S20-1300-12	1	Intermediate flange
19	T04S20-0250-12	2	Handle	50	T04S20-8810-12	2	Pillar, front
20	T04S20-1000-16	1	Carrier shaft	51	T04S20-8811-12	1	Pillar, rear
21	T04S20-3200-25	1	Feather key	52	SCN25-AP	1	Adapter plate
22	T04S20-3100-80	1	Radial shaft sealing ring	53	M04S20-8813-12	2	Hexagon nut
23	T04S20-2900-25	3	Cylinder bolt	55	T04S20-3010-80	1	O-ring, bearing housing
24	T04S20-3000-80	1	O-ring, cover	56	T04S20-8813-12	1	Hexagon nut
25	T04S20-2600-25	1	Tapered roller bearing				

8.2 SCN25 / SCN40 with parts list

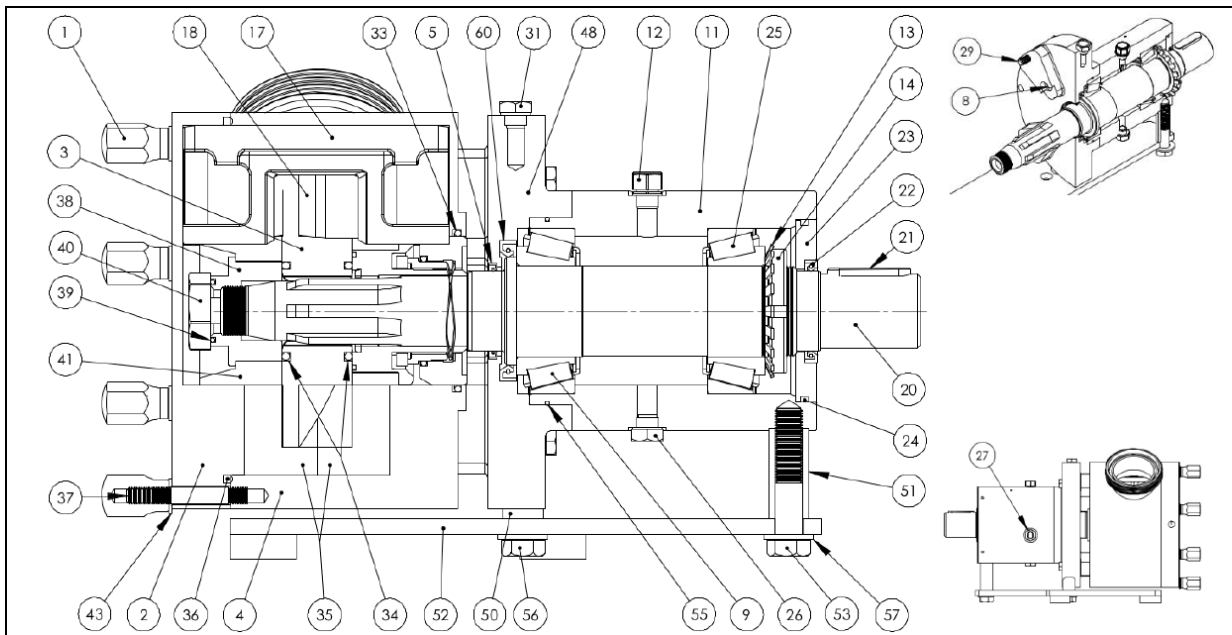

Item	Product number	Units	Description	Item	Product number	Units	Description
1	T04S_-1600-12	4	Cap nut	29	T04S_-1901-12	2	Hexagon screw
2	T04S_-0200-10	1	Front cover	31	T04S_-3901-25	1	Ring screw
3	T04S_-0100-10	1	Rotor	33	T04S_-1750-84	1	O-ring, pump housing
4	T04S_-0300-10	1	Pump housing	34	T04S_-1751-84	2	O-ring, rotor
5	T04S_-2301-80	1	Radial shaft sealing ring	35	T04S_-1200-50	2	Stator
8	T04S_-2201-12	4	Cylinder bolt	36	T04S_-1701-84	1	O-ring, front cover
9	T04S_-2400-25	1	Tapered roller bearing	37	T04S_-1800-10	4	Stud screw
11	T04S_-1405-10	1	Bearing housing	38	T04S_-0820-10	1	Locking nut
12	T04S_-6000-51	1	Bleeder valve	39	T04S_-1752-84	1	O-ring locking nut
13	T04S_-2700-25	1	Safety plate	40	T04S_-1100-10	1	Locking screw
14	T04S_-2800-25	1	Shaft nut	41	T04S_-0960-55	1	Front bearing
17	T04S_-0701-10	1	Guide cartridge	43	T04S_-1601-12	7	Washer
18	T04S_-0400-49	1	Scraper	48	T04S_-1306-12	1	Intermediate flange
20	T04S_-1000-16	1	Carrier shaft	50	T04S_-8815-12	2	Supporting foot, short
21	T04S_-3200-25	1	Feather key	51	T04S_-8816-12	1	Supporting foot, long
22	T04S_-3100-80	1	Radial shaft sealing ring	52	SCN25-AP	1	Adapter plate
23	T04S_-1500-50	1	Cover	53	T04S_-8820-12	1	Hexagon screw
24	T04S25-1753-80	1	O-ring, cover	55	T04S_-3011-80	1	O-ring, bearing housing
24	T04S40-1750-25	1	O-ring, cover	56	T04S_-8821-12	2	Hexagon screw
25	T04S_-2600-25	1	Tapered roller bearing	57	T04S_-8822-12	3	Washer
26	T04S_-3700-12	1	Oil drain screw	60	T04S_-2302-80	1	Radial shaft sealing ring

Figure 16 Sectional drawing SCN25 / SCN40

8.3 SCN25D / SCN40D with parts list

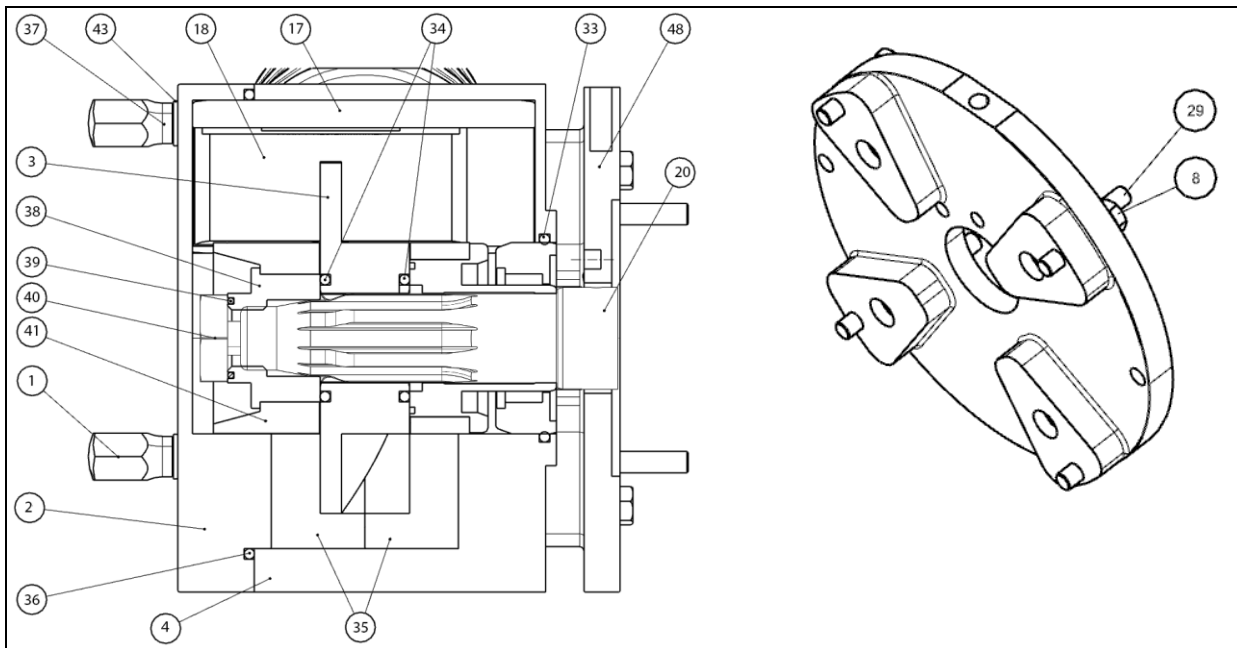

Item	Product number	Units	Description	Item	Product number	Units	Description
1	T04S__-1600-12	4	Cap nut	34	T04S__-1751-84	2	O-ring, rotor
2	T04S__-0200-10	1	Front cover	35	T04S__-1200-50	2	Stator
3	T04S__-0100-10	1	Rotor	36	T04S__-1701-84	1	O-ring, front cover
4	T04S__-0300-10	1	Pump housing	37	T04S__-1800-10	4	Stud screw
8	T04S__-2201-12	4	Cylinder bolt	38	T04S__-0820-10	1	Locking nut
17	T04S__-0701-10	1	Guide cartridge	39	T04S__-1752-84	1	O-ring, locking nut
18	T04S__-0400-49	1	Scraper	40	T04S__-1100-10	1	Locking screw
20	T04S__-1000-16	1	Carrier shaft	41	T04S__-0960-62	1	Front bearing
29	T04S__-1901-12	2	Hexagon screw	43	T04S__-1601-12	7	Washer
33	T04S__-1750-84	1	O-ring, pump housing	48	T04S__-1306-12	1	Intermediate flange

Figure 17 Sectional drawing SCN25D / SCN40D

8.4 Face seal

8.4.1 Face seal SCN20

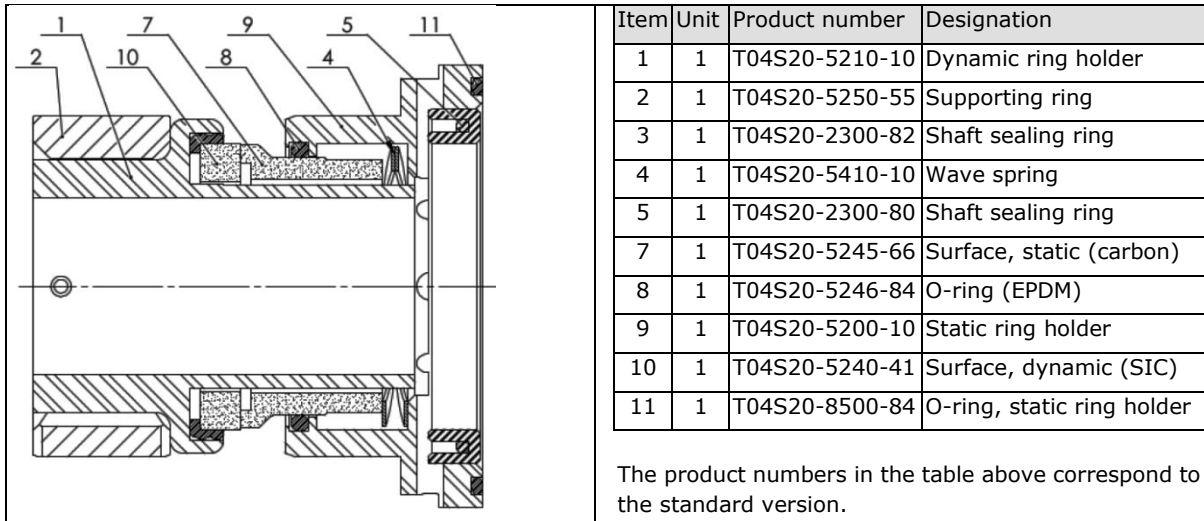

Figure 18 Sectional view, face seal SCN20

8.4.2 Face seal SCN25 / SCN40

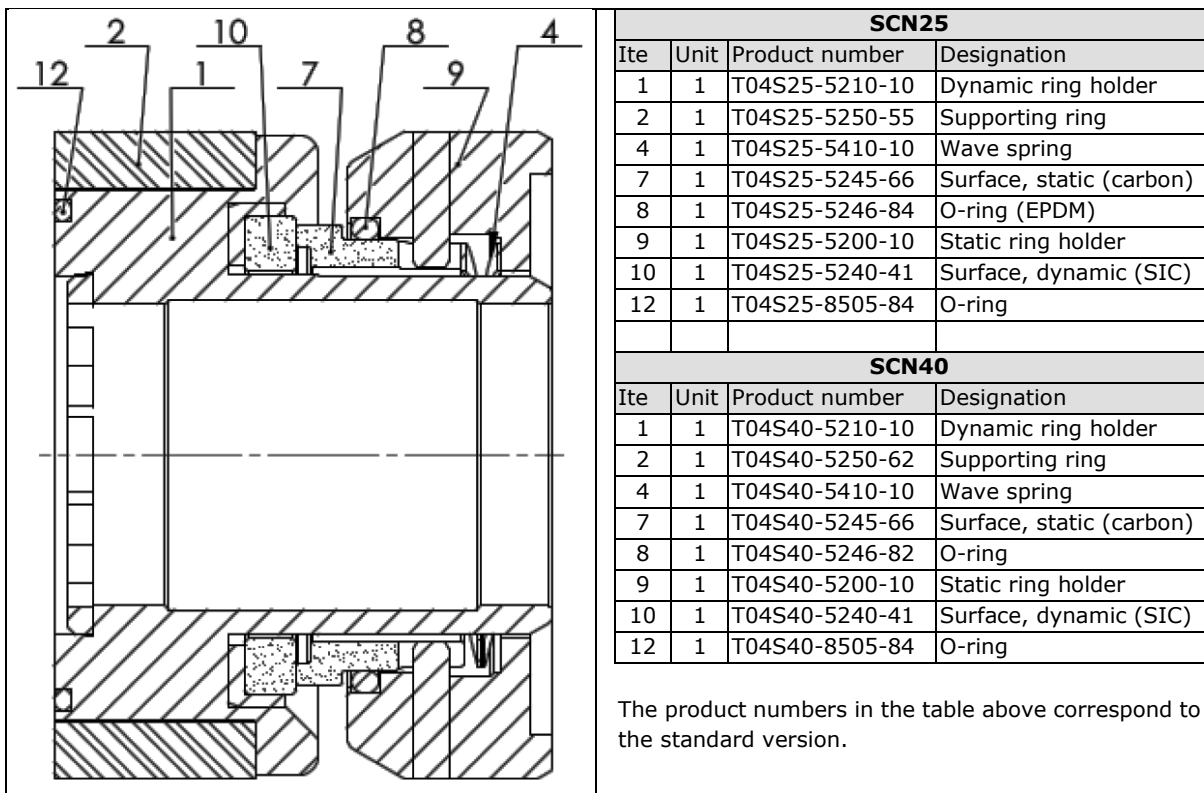

Figure 19 Sectional view, face seal SCN25 / SCN40

8.4.3 Face seal SCN25D / SCN40D

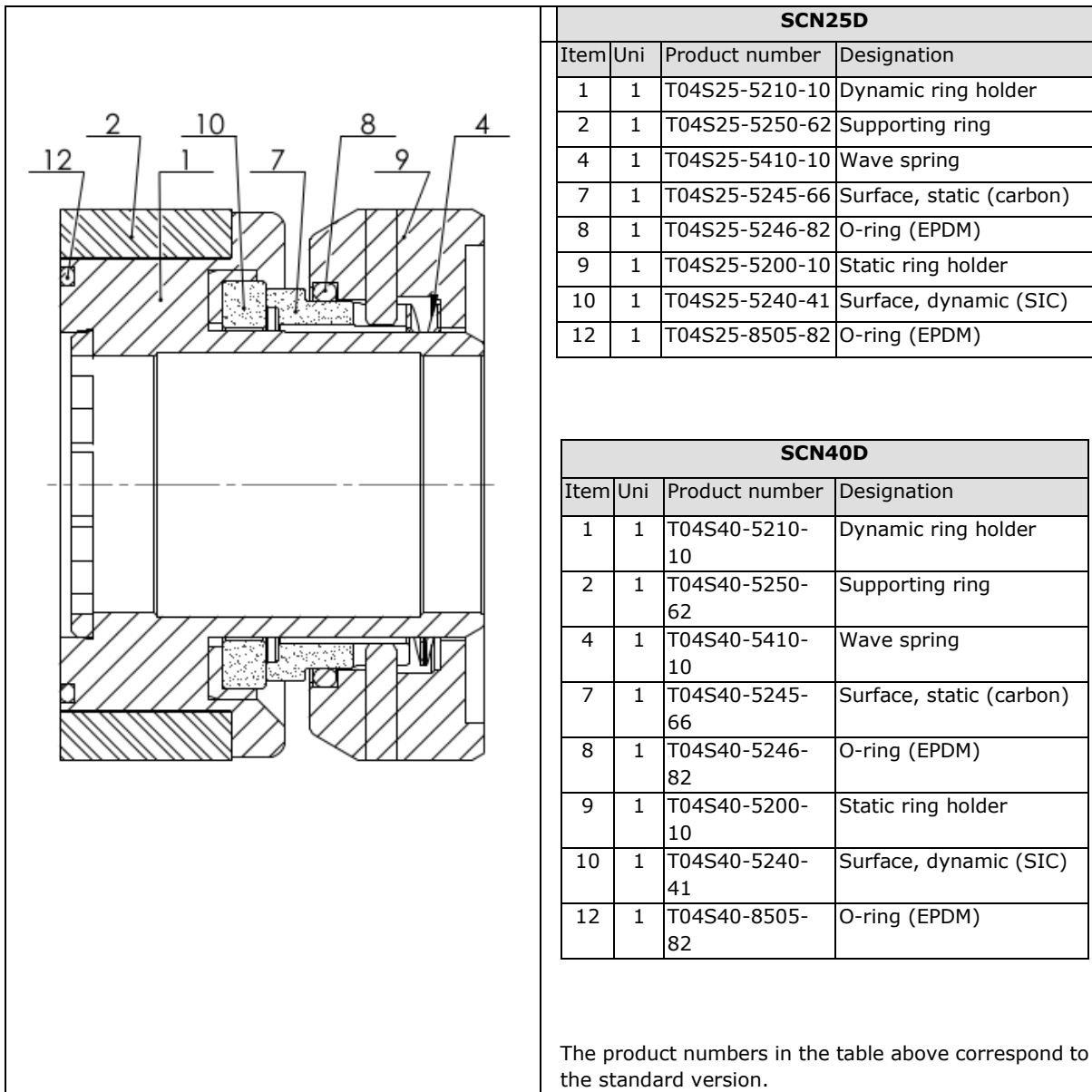

Figure 20 Sectional view, face seal SCN25D

8.5 Shaft sealing ring system

8.5.1 Shaft ring seal (3x) SCN / SCN-D Serie

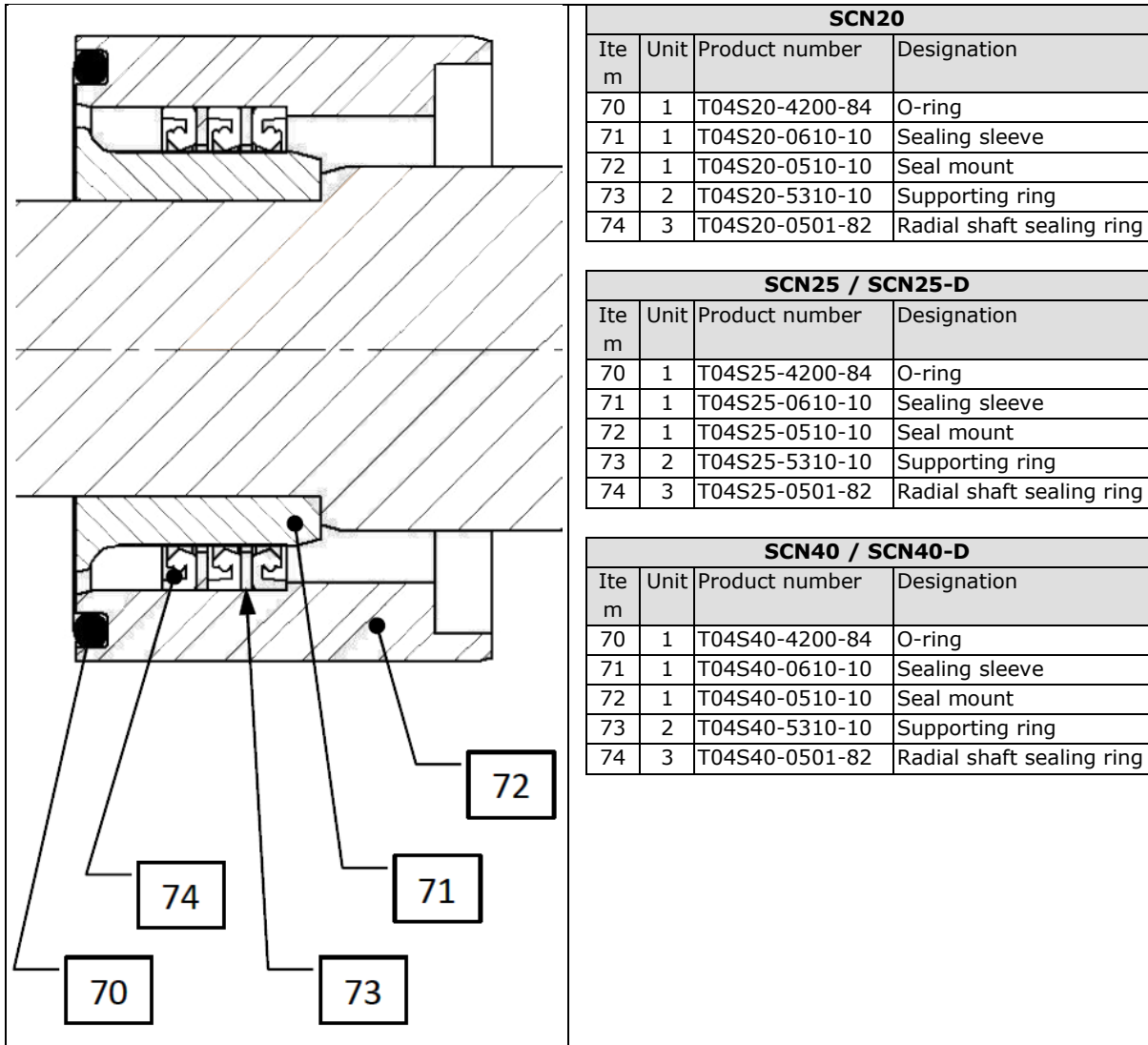

Figure 21 Shaft ring seal

8.6 Dimensioned drawing

8.6.1 SCN Series

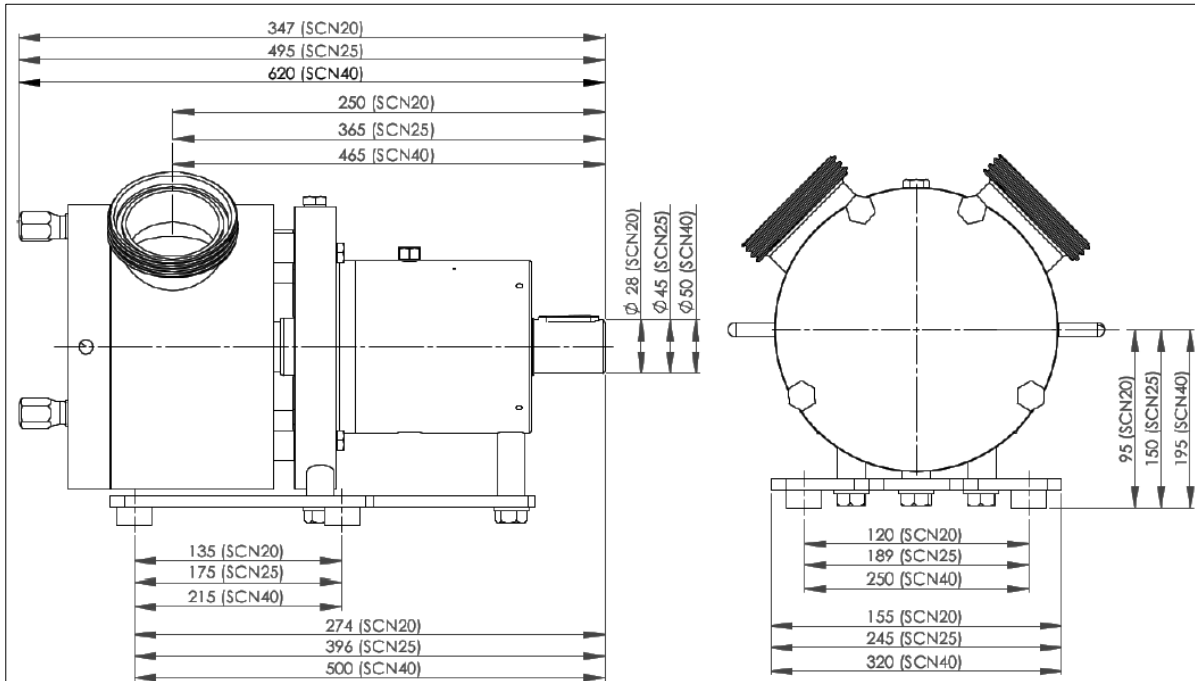

Figure 22 Pump dimensions

8.6.2 SCN D Series

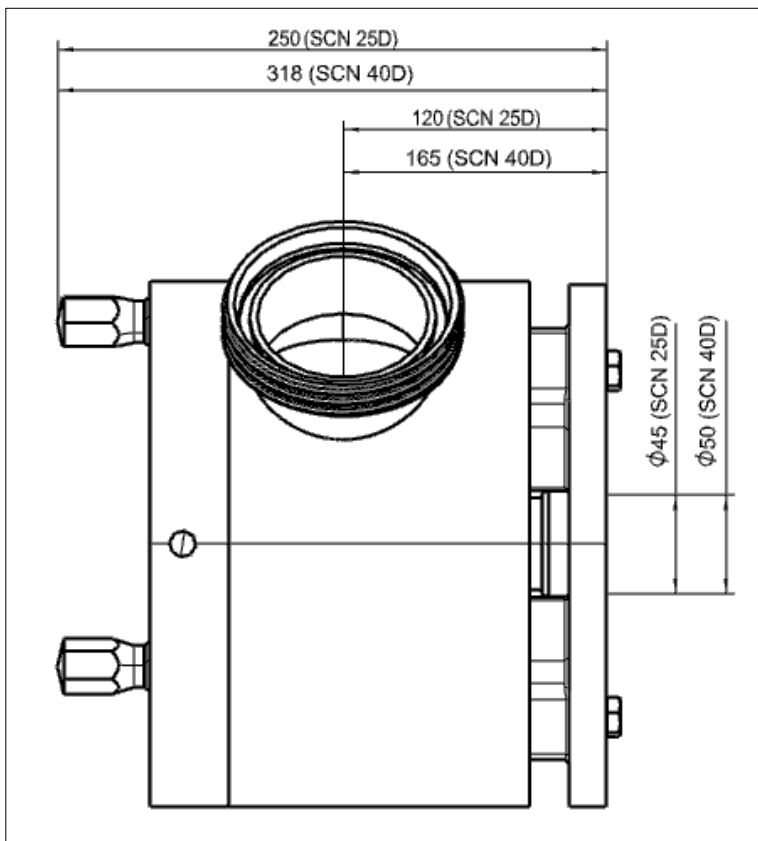

Figure 23 Pump dimensions

9 Static rinsing equipment



Benefits:

1. Product shielding from the atmosphere.

Explanation: If a product hardens in the air or is contaminated (polluted) by air, this is prevented by the use of static rinsing equipment.

2. Indicator for leakage in sealing system

Explanation: If a leakage occurs in the sealing system, rinsing medium will emerge from the pipe bend and indicates this.

Figure 24 Static rinsing equipment

10 Index

10.1 List of figures

<i>Figure 1 Hazards</i>	18
<i>Figure 2 Connector position</i>	21
<i>Figure 3 Rotating the pump housing</i>	22
<i>Figure 4 Rotating the pump housing</i>	22
<i>Figure 5 Rotating the pump housing SCN-D</i>	22
<i>Figure 6 Changing rotational direction</i>	23
<i>Figure 7 Commissioning - Dry running condition</i>	24
<i>Figure 8 Sealing system for adjustment dimension "X"</i>	28
<i>Figure 9 Adjustment dimension "X"</i>	28
<i>Figure 10 Spacer ring installation</i>	29
<i>Figure 13 Cleaning in own circuit</i>	36
<i>Figure 13 Cleaning in the CIP circuit</i>	37
<i>Figure 16 Sectional drawing SCN25 / SCN40</i>	48
<i>Figure 17 Sectional drawing SCN25D / SCN40D</i>	49
<i>Figure 18 Sectional view, face seal SCN20</i>	50
<i>Figure 19 Sectional view, face seal SCN25 / SCN40</i>	50
<i>Figure 20 Sectional view, face seal SCN25D</i>	51
<i>Figure 21 Shaft ring seal</i>	52
<i>Figure 22 Pump dimensions</i>	53
<i>Figure 23 Pump dimensions</i>	54
<i>Figure 24 Static rinsing equipment</i>	55

10.2 List of tables

<i>Table 1 Maximum pump limit values</i>	17
<i>Table 2 Oil change - filling quantities</i>	23
<i>Table 3 Adjustment dimension</i>	24
<i>Table 4 Spacer ring sets</i>	25
<i>Table 5 Oil change - Connection for flushing</i>	30
<i>Table 6 Torques (screws)</i>	32

