

‘PC’ PUMPS OPERATOR’S MANUAL & PARTS LIST for End-Suction Centrifugal Pumps (Non-Self Priming)

OPERATION AND
SERVICE GUIDE
PO-1775F
Sept. 2006

Before reading or using this manual be certain of the material of construction of your pump. Check the model number label on the pump as follows:

POLYESTER	pumps have model numbers beginning with PCE and price codes beginning with 60-1.
POLYPROPYLENE	pumps have model numbers beginning with PCP and price codes beginning with 60-2.
RYTON	pumps have model numbers beginning with PCR and price codes beginning with 60-3.
NORYL	pumps have model numbers beginning with PCN and price codes beginning with 60-4.

SAFETY WARNING

Verify the chemical compatibility of the materials of your pump with the liquid you want to pump. If you are uncertain regarding chemical compatibility, contact your dealer for applications assistance and request a copy of our Corrosion Resistance Charges. Do not use a pump that is not chemically compatible with the liquid you intend to pump or serious bodily injury, death, fire, explosion, or environmental damage could result.

ALSO, PLEASE READ SECTION I, II AND III BEFORE OPERATING PUMP.

I. Safety Precautions.....	2
II. Preparing the Pump for Operation	3
III. Pump Operating Instructions.....	4

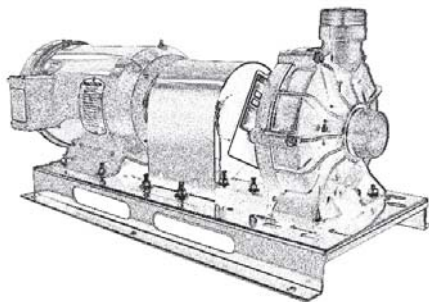

2", Electric Drive Flexible (Long) Coupled

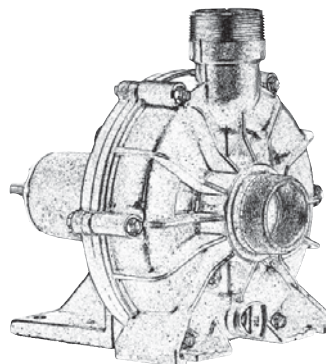

3" Cast Iron Pedestal Mount

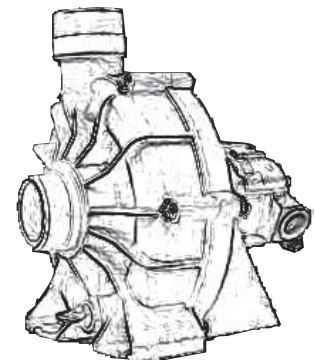

2", Hydraulic Drive Close-Coupled

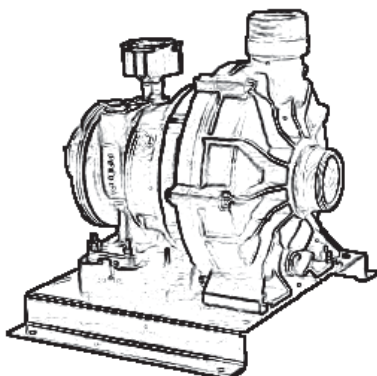

1½" / 2" Pneumatic Drive Close-Coupled

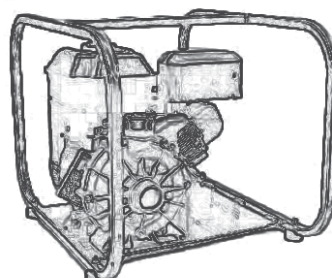

1½"/2" Engine Drive Close-Coupled

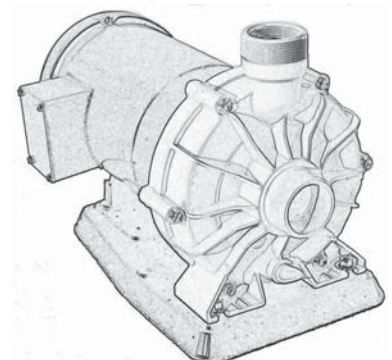

1½" / 2" Electric Drive, Close-Coupled

OPERATOR'S MANUAL FOR: END-SUCTION CENTRIFUGAL PUMPS

Table of Contents

PLEASE READ SECTIONS I, II AND III BEFORE OPERATING PUMP.

	Page no.
I. Safety Precautions.....	2
II. Preparing the Pump for Operation	3
III. Pump Operating Instructions.....	4
IV. Pump Trouble Shooting and Repair	4
V. Pump Disassembly and Repair	4
VI. Special Information:	
A. Flexible-coupling: Coupling Alignment.....	5
1. Couplings	
2. Baseplate Kits	
B. Close-coupled Electric Motor and Pneumatic Motor Driven Pumps	6
C. Pump Dimensions	6 & 7
VII. Pump Parts List and Parts Diagram.....	8 - 10

OPERATOR'S MANUAL

I. SAFETY PRECAUTIONS

WARNING:

1. Never use these pumps for pumping flammable liquids such as gasoline. **AN EXPLOSION AND SERIOUS INJURY MAY RESULT IF THIS WARNING IS IGNORED.**
2. In pumping corrosive materials, extreme caution should be exercised. Provide safety guards, ventilation, and drains to protect people and property in case of a leak in the pump. Handling instructions from the manufacturer(s) of the liquids being pumped should be closely followed.
3. Before starting the pump, follow all of the instructions in this manual and any supplemental instructions supplied with the pump.
4. Any person operating this pump and its power unit should be fully aware of its safe operation before they start using it.
5. Never operate an engine-driven unit in an explosive atmosphere, near combustible materials, or where insufficient ventilation exists unless specific provisions have been made regarding the power unit so as to prevent possible injury and damage. Be certain any other power unit is safe for the area in which it is to be operated.
6. Always be sure that the unit is on a secure footing and keep the immediate pump and power unit area free of all unauthorized personnel. If the pump is sitting beside a pit, be sure it is well anchored so that it does not fall in.
7. Never operate the unit with any guards removed.
8. With engine-driven pumps:
 - a. Observe all safety precautions for the handling of fuel.
 - b. Never refuel the engine while running, and care should be exercised so that no fuel is spilled on a hot engine. Always allow engine to cool at least two minutes before refueling.
9. Before working on this pump make sure that the power unit cannot inadvertently be started.
10. Be sure that the power unit, pump, wiring and piping installations are suitable for the liquid being pumped, and comply with all applicable codes and regulations.
11. Do not use torches or apply fire or flames to this pumps for any reason.
12. This pump must not be subjected to more than 65 pounds per square inch internal pressure. The pump itself, normally cannot develop more than 55 pounds per square inch pressure. The pump *must not* be used under any of the following unusual conditions which can result in excessive pressures being developed:
 - A. Pump shaft speed over 3600 RPM.
 - B. Quick closing valves in discharge line or any other device which may introduce hydraulic shock into the system.
 - C. Possible sudden obstruction of discharge line such as vehicle driving over hose.
 - D. High positive suction pressures (such as with a flooded suction) which would increase the *total system* pressure to 65 PSI or above.
 - E. Do not pump liquids with specific gravities exceeding the following values:

Impeller* Number	Maximum Specific Gravity** at 3600 RPM
667	2.1
707	1.6
709	1.6
975	2.1

*The impeller curve letter appears in the model number on the pump label. It is the fifth digit of the model number.

**The specific gravity is the ration of the weight of the liquid to be pumped to the weight of an equal volume of water. Water has a specific gravity of 1.0. Therefore, a liquid which is heavier than water has a specific gravity greater than 1.0.

13. Do not overtighten the drain plug. Hand tighten only. Excessive force may damage the threads or the pump body. Do not use a metal plug.

14. Use at least one foot of flexible hose to make plumbing connections to the pump. Rigid piping may put stresses on the pump, causing damage. If rigid piping must be used, properly support it so as to eliminate stresses on the pump.

15. **Do not tighten inlet and discharge fittings more than one turn beyond hand tight. Excessive force will damage the pump or fittings. Use teflon sealing tape on all threaded fittings.**
16. Long suction and discharge hoses or pipes must be supported so that the weight of the hoses or pipes filled with liquid does not damage the pump or tip it over.
17. Use replacements parts supplied by the manufacturer only.
18. **Do not run the pump dry.** Always fill the system with liquid to be pumped before starting the pump. The system consists of the pump and suction line. If the pump has a 'flooded suction' (the liquid to be pumped is above the pump itself) then the pump and suction line will be filled by the liquid to be pumped. If the pump is on a 'suction lift' (the liquid to be pumped is below the pump) then it will be necessary to install a foot valve at the end of the suction line so that the foot valve is completely immersed in the liquid to be pumped. In the case of a suction lift situation,

it is necessary to fill the suction line and the pump (referred to as the system) before starting the pump. A non-self-priming centrifugal pump can only pump if the system is full of liquid and the pump encounters no air. It is not necessary to drain the pump after use, unless there is danger of freezing, settling of solids, or crystallization.

19. Do not subject pump to extreme conditions of acidity or basicity. Consult factory for specific recommendations concerning chemicals and temperatures.
20. Do not operate pump with closed discharge valve for any lengthy period of time. Liquid in pump will overheat. If necessary to reduce pump flow without lowering the speed (RPM), a valve may be used in the discharge line to throttle the flow.
21. Do not restrict the suction line or try to throttle the pump on the suction side because cavitation may result. Cavitation is evidenced by noisy pump operation and pitting of pump parts.

II. PREPARING THE PUMP FOR OPERATION

Pump Preparation

1. Inspect unit for shipping damage immediately upon receipt and before signing for merchandise. If any visible damage exists, not damage on shipping bill of lading or receiving document(s) before signing. Also, notify your dealer or distributor immediately of any damage to the shipment.
2. Read these instructions and the power unit instructions until you are sure you can operate it safely and correctly.
3. **IMPORTANT INFORMATION ABOUT PUMP ELASTOMERS ("RUBBER PARTS").**

This pump is equipped with one of the three following elastomeric materials. Please read the label on the pump for the name of the specific type of elastomer used inside the pump.

BUNA-N ELASTOMERS

This pump is equipped with BUNA-N elastomers ("rubber parts"). BUNA-N material is suitable for use with water (clean and dirty) and other non-hazardous liquids. Consult factory for additional specific non-hazardous application recommendations.

EPDM ELASTOMERS

This pump is equipped with EPDM shaft seal and EPDM static seals. These elastomers ("rubber parts") are suitable for use with water (clean or dirty) and many non-hazardous agricultural and industrial chemicals. Consult the factory for specific non-water application recommendations.

VITON ELASTOMERS

This pump is equipped with Viton elastomers ("rubber parts"). Viton material is suitable for use with water (clean or dirty), and many non-hazardous agricultural and industrial chemicals. However, due to the wide range of chemical solutions, it is not possible to list them all here. Consult the factory for specific non-water application recommendations.

Power unit preparation - Gasoline engine-driven pumps:

1. For complete operating and maintenance information, consult the engine manufacturer's instructions included with the pump.
2. Before starting, fill crankcase with oil specified by the engine manufacturer. Use a high quality detergent oil classified for service SC, SD, SE, or SF. Do not add anything to the recommended oil.
3. Before starting, fill fuel tank with clean, fresh, unleaded grade automotive gasoline. *Do Not* mix oil with gasoline.

CAUTION: Always remove spark plug or spark plug wire before working on unit to prevent accidental starting.

CAUTION: The engine governor is set at the factory. Do not tamper with any part which may increase the governed engine speed.

WARNING

The engine exhaust from this product contains chemicals known to the State of California to cause cancer, birth defects, or other reproductive harm.

Power unit preparation - Electric Motors:

1. Make certain the input power to your electric motor is proper, single phase or three phase, and is of the proper voltage according to the motor specification plate.
2. *Be sure of the proper motor rotation.* Pump impeller should rotate counterclockwise, looking from the suction inlet side. For single phase motors, consult the motor manufacturer's instructions for wiring for counterclockwise rotation. Three phase motor rotation may be reversed by interchanging any two of the three power leads.
3. Make certain that wiring for your electric motor complies with all existing local codes.

Power unit preparation - Hydraulic and Pneumatic Motors:

Consult the separate instruction sheet supplied with each hydraulic or pneumatic motor powered unit.

Power requirements:

NOTE: For liquids have specific gravities greater than 1.0, increase the rated horsepower (from catalog) by a factor equal to the specific gravity of the liquid being pumped.
(Ex. Catalog HP x Specific gravity = Actual HP required).

III. PUMP OPERATING INSTRUCTIONS

1. Fill the system with liquid before starting. Do not run the pump dry; damage to the mechanical shaft seal may result. There are no points on the pump which need lubrication. The mechanical shaft seal is self lubricating, and designed to handle clean liquids.
2. Make certain all pipe or hose connections are air tight. An air leak in the suction line under 'flooded suction' operations will reduce flow. An air leak in the suction line on a 'suction lift' installation will prevent operation.
3. Always place the pump as close to the liquid to be pumped as possible. Keep all lines as short and straight as possible. Avoid sharp bends in hoses. Keep the pump on a level foundation.
4. If flexible hose must be laid across a roadway, protect it with planking. Instantaneous shut off pressures applied when a vehicle runs across an unprotected hose will cause "hydraulic shock". This shock can damage the pump and/or damage the hose. See Figure #1.
5. When pumping dirty water or other liquids which may contain solids, always use a pump strainer specified by the manufacturer on the end of the suction line. In the case of 'suction lift' conditions, the strainer will have to be a combination foot valve and strainer.
6. Drain the pump whenever there is danger of freezing.
7. Always use rubber feet under portable pump when operating on a hard surface. This will prevent damage to the pump and power unit.
8. Always flush out the pump at the end of operation if the liquid being pumped may leave a solid or sticky residue in the pump. If this is not done, damage to the pump may result.

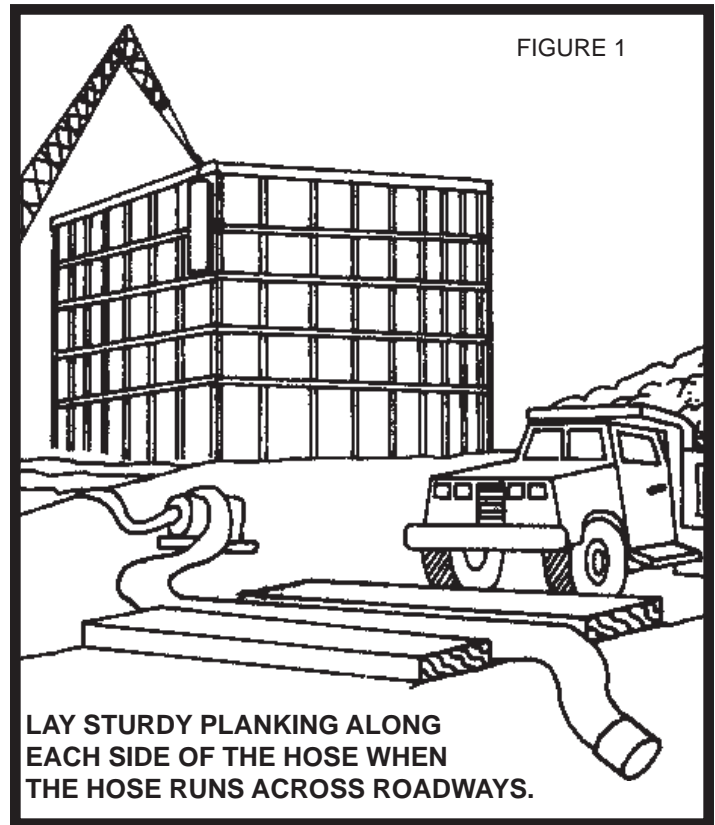

IV. PUMP TROUBLE SHOOTING AND REPAIR

PROBLEM

1. Pump does not produce flow or has insufficient flow.

POSSIBLE CAUSE

- a. Pump and suction line not completely filled. See Section I, paragraph #18.
- b. Leak in suction line.
- c. Foot valve and strainer not completely immersed.
- d. Mechanical shaft seal leaking air.
- e. Impeller rotation incorrect (impeller should rotate counterclockwise when viewing through suction end).
- f. Impeller speed (RPM) too low.
- g. Worn impeller and/or volute. See Section V, paragraphs 4, 5, and 6.

V. Pump Disassembly and Repair

NOTE: Pump may be disassembled and repaired using simple "screwdriver maintenance". See exploded view drawing at end of manual for item numbers mentions.

1. Remove the six ¼" volute screws and nuts (items 21 & 4) and remove the volute (item 17).
2. Remove the large o-ring (item 7) from around the bracket (item 6).
3. Unscrew the impeller screw (item 16) and remove it along with the small o-ring (item 8). Slide the impeller (item 16) and key (item 27) off the shaft. (To facilitate removal of impeller, gently force two screwdrivers 180° apart under the back of the impeller and gently pry the impeller off the shaft).

NOTE: Impeller shims (item 30) may or may not have been used on your pump. Check for these and save them for reuse.

4. One-half of the shaft seal (item 14) is in the impeller hub (item 15), and the other half (item 13) is mounted in the bracket (item 6) where the shaft protrudes. Only remove the impeller portion of the seal and the bracket portion of the seal if you intend to replace both seal elements with new parts. Always protect the sealing surfaces from nicks, scratches and dirt.

5. Remove the four bracket screws (item 9) and the four small o-rings (item 8), one on each screw. The bracket (item 6) may now be removed. The bracket (stationary) portion of the shaft seal (item 13) may now be **pressed** out from the backside of the bracket. Use a round wooden plug 1-3/16" in diameter and carefully press the seal out straight. If it is to be reused, carefully check the face for nicks or scratches. If no damage is evident, carefully store for reinstallation. Save the o-ring (item 11) which surrounds the seal.

NOTE: If plugs (item 12) are installed over the bracket screw heads (item 9), remove by screwing a volute screw (item 21) into the plug and carefully pulling out. **Be careful not to strip the threads which the screw forms in the plug.**

REASSEMBLY - READ THE FOLLOWING INSTRUCTIONS BEFORE REASSEMBLY.

Reassembly involves putting the pump together in the reverse order of the disassembly sequence described above.

1. When installing a new seal, always replace both elements (items 13 & 14) and install the o-ring (item 11) around the bracket half of the seal (item 13). Do not bear directly on the seal surface when installing the bracket half. Use a piece of pipe that will bear only on the metal flange of the seal case. The impeller half of the seal (item 14) may be pressed in with the thumbs. Be sure both seal halves are seated squarely with respect to the pump shaft.
2. During final assembly it is recommended that the 5 screw head o-rings (item 8) be replaced. Lubricate these with a **vegetable** type oil only. (DO NOT use petroleum based oil).
3. Use a thread locking compound such as Loctite #242 on the bracket screw (item 9) threads and on the impeller screw (item 16) threads.
4. The clearance between the impeller (item 15) vanes and the volute (item 17) face should be about .015" to .025" for good performance. This "front" clearance can be obtained by shimming with the washer type shims (item 30) mentioned in step 3 of the disassembly instructions. Use the same shims which you saved from step 3. Install the impeller (item 15) and firmly press on the impeller (**hub only**) while rotating the impeller 360°. If scraping is heard, add shim or shims until scraping noise is not heard. Install the impeller screw and o-ring (items 16 & 8). Install the volute (item 17) and the screws and nuts (items 21 & 4).

5. Rotate the shaft while listening for scraping noise. If scraping is heard, remove the volute and impeller and remove one washer type shim. Repeat this procedure until no scraping is heard.
5. Check the impeller vanes for proper height. The following measurements should be found when measuring the vane height at the outside perimeter of the impeller (vane tip):

*IMPELLER NO.	VANE HEIGHT AT TIP OF VANE
58-0667	.535"
58-0704	.535"
58-0706	.535"
58-0707	.535"
58-0708	.535"
58-0709	.535"
58-0975	.975"

*See parts list for further description. The impeller curve letter is the fifth digit of the model number on the pump label. The impeller part number is located on each curve on the flow charts or on the impeller itself.

VI. SPECIAL INFORMATION

A. FLEXIBLE COUPLED PUMPS: COUPLING ALIGNMENT

Measure the diameter of the pump shaft and power unit shaft. Choose the appropriate coupling for your pump and power unit. (See flexible couplings charge number VI-A). Proper shaft and coupling alignment reduces vibration and prevents premature coupling failure. The following 8 steps help in obtaining proper shaft alignment.

1. Make sure you use a rigid base plate large enough for the assembly of the pump and the drive unit. We offer kits, 58-0028 and 58-0016, for this purpose. (See base plate kits listed after couplings charge VI-A).**

6. Place the coupling halves over each shaft, put the "spider" between the two halves and couple the two halves together.
7. To assure parallel alignment (Figure 5) place a straight edge along the side of both coupling halves in two different locations, 90° apart. The coupling is aligned when the straight edge rests squarely on the sides of both coupling halves.

POWER COUPLING PART NUMBER	ELECTRIC UNIT SHAFT* DIAMETER	MOTOR FRAME SIZES
58-0785	.625"	56
58-0786	.875"	143T-145T 182-184
58-0787	1.125"	182T-184T 213-215
58-0788	1.375"	213T, 215T

FLEXIBLE-COUPPLINGS CHART VI-A

*One-half of each coupling has a .750" diameter bore to fit the pedestal pump shaft.

2. Place the pump and drive unit on the base plate.
3. Measure the distance between the center line of the pump shaft and the base plate surface.
4. Measure the distance between the center line of the drive unit shaft and base plate.
5. Compare measurements obtained from steps 3 and 4 and use spacer blocks for height adjustment to insure alignment of both shafts.

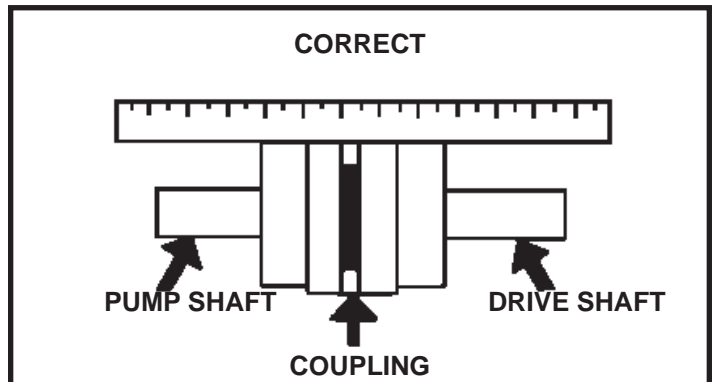
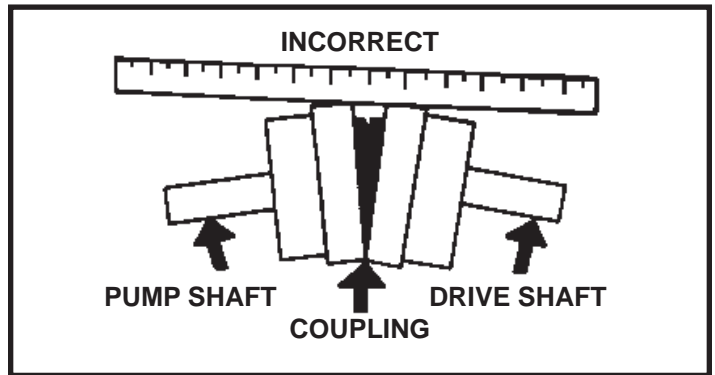

FIGURE 5

8. To avoid angular misalignment, insert a measuring device (taper gauge or feeler gauge) between the coupling faces at four locations 90° apart (See arrows in Figure 6) and measure the gap at each of the four locations. For proper alignment all four measurements should be equal. Reshimming may be required to achieve this alignment.

****BASEPLATE KITS**

These kits contain a baseplate, coupling guard, shims and hardware for mounting a pedestal pump to the power units listed. All necessary mounting holes are provided in the baseplate.

58-0028 - Light duty baseplate for these electric motor frame sizes: 56, 143T, 145T, also can be used to mount a 3.5 to 6.5 HP gasoline powered engine.

58-0016 - Heavy duty baseplate for these electric motor frame sizes: 184, 182T, 184T, 213T, 215T.

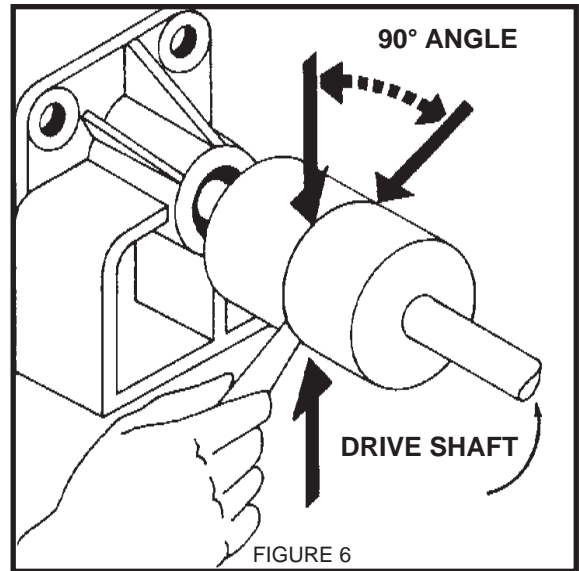

B. CLOSE-COUPLED ELECTRIC AND PNEUMATIC MOTOR DRIVEN PUMPS

If the motor shaft adapter is replaced, use the mounting dimensions shown when installing the new part.

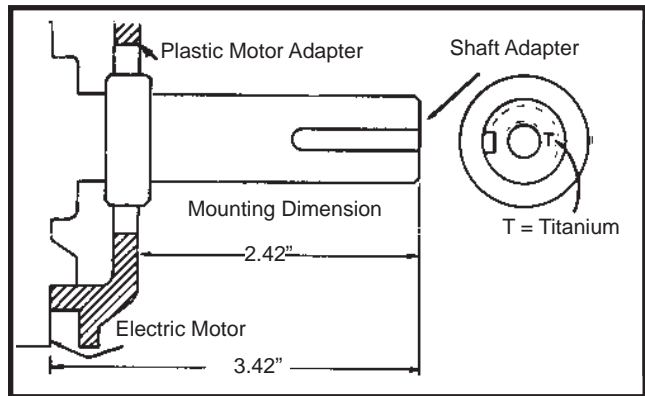

C. PUMP DIMENSIONS

Ø OF CENTRAL DISCHARGE PORT - SEE NOTE 1

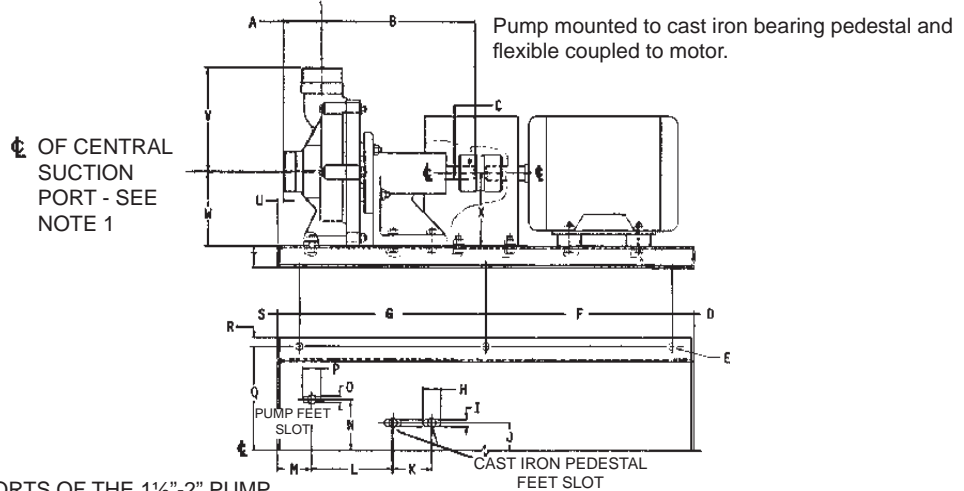

NOTE:
1) THE SUCTION AND DISCHARGE PORTS OF THE 1½"-2" PUMP FEATURE 1½" NPT FEMALE THREADS (INTERIOR) AND 2" NPT MALE THREADS (EXTERIOR). THE SUCTION AND DISCHARGE PORTS OF THE 3" PUMP FEATURE 3" NPT MALE THREADS (EXTERIOR) ONLY.

Pump Size	A	B	C	D	E	F	G	H	I		
1½"-2"	2.20	9.0	.750 Dia	1.275	.406 Dia	10.85	10.85	1.056	.406		
3"	2.17	9.25	.750 Dia	1.275	.406 Dia	10.85	10.85	1.056	.406		
Pump Size	J	K	L	M	N	O	P	Q	R	S	T
1½"-2"	1.61	2.25	4.72	2.24	2.95	.406	1.056	6.0	.50	1.275	1.25
3"	1.61	2.25	5.05	2.24	2.95	.406	1.056	6.0	.50	1.275	1.25
Pump Size	U	V	W	X							
1½"-2"	.630	5.98	4.17	4.17							
3'	.590	6.50	4.17	4.17							

Dimensions are in inches

☺ OF CENTRAL DISCHARGE PORT - SEE NOTE 1

☺ OF CENTRAL SUCTION PORT - SEE NOTE 1

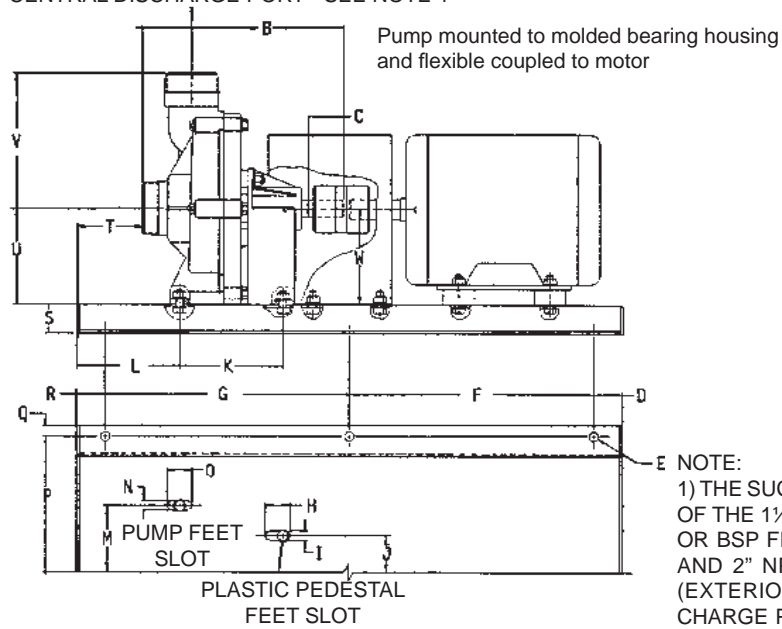

E NOTE:
1) THE SUCTION AND DISCHARGE PORT OF THE 1½"-2" PUMP FEATURE 1½" NPT OR BSP FEMALE THREADS (INTERIOR) AND 2" NPT OR BSP MALE THREADS (EXTERIOR). THE SUCTION AND DISCHARGE PORTS OF THE 3" PUMP FEATURE 3" NPT OR BSP MALE THREADS (EXTERIOR) ONLY.

Pump Size	A	B	C	D	E	F	G	H	I		
1½"-2"	2.20	6.80	.750 Dia	1.275	.406 Dia	10.85	10.85	1.056	.406		
3"	2.17	7.14	.750 Dia	1.275	.406 Dia	10.85	10.85	1.056	.406		
Pump Size	J	K	L	M	N	O	P	Q	R	S	T
1½"-2"	1.61	4.65	4.55	2.95	.406	1.506	6.0	.50	1.275	1.25	2.94
3"	1.61	4.99	4.55	2.95	.406	1.506	6.0	.50	1.275	1.25	2.90
Pump Size	U	V	W								
1½"-2"	4.17	5.98	4.17								
3"	4.17	6.50	4.17								

Dimensions are in inches

☺ OF CENTRAL DISCHARGE PORT - SEE NOTE 1

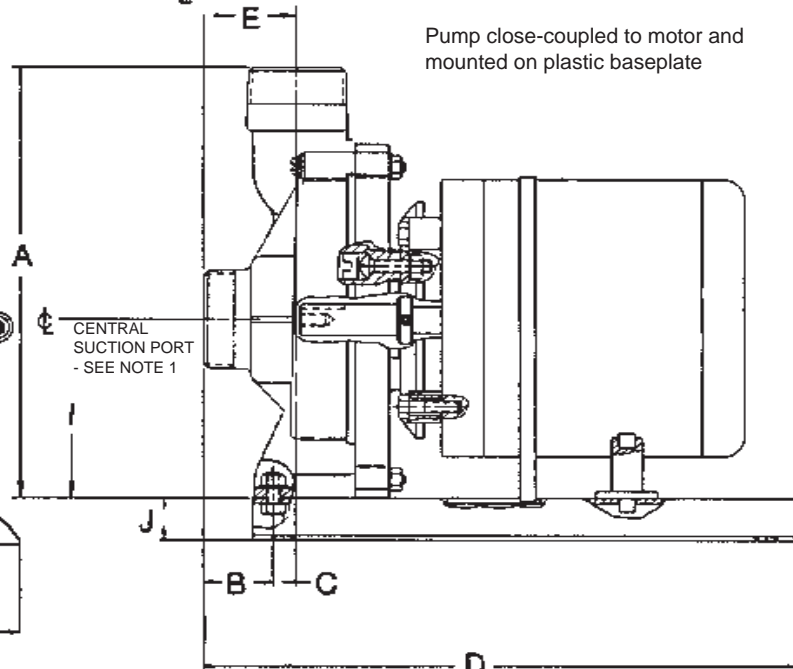
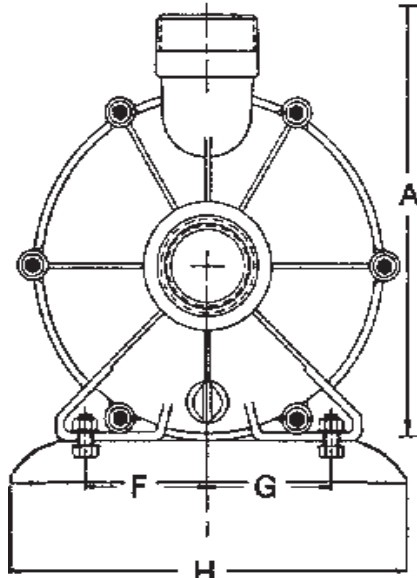

NOTE:

1) THE SUCTION AND DISCHARGE PORTS OF THE 1½"-2" PUMP FEATURE 1½" NPT FEMALE THREADS (INTERIOR) AND 2" NPT MALE THREADS (EXTERIOR). THE SUCTION AND DISCHARGE PORTS OF THE 3" PUMP FEATURES 3" NPT MALE THREADS (EXTERIOR) ONLY.

Pump Size	A	B	C	D	E	F	G	H	I	J
1½"-2"	10.16	1.69	.265	13.75	2.20	2.95	2.95	8.75	4.17	1.12
3"	10.67	1.65	.265	13.75	2.17	2.95	2.95	8.75	4.17	1.12

VII. 'PC' PUMP PARTS LIST

ITEM #	PART #	PART DESCRIPTION	QTY./PUMP
4	58-0721 10F	FLANGE NUT, Body, Stainless Steel, 1/4-20 Hex, for Polypropylene pumps only	6
	58-0721 10	NUT, Body, Stainless Steel, 1/4"-20 Hex	6
6	58-1016 20	BRACKET, NORYL, gray	1
	58-1016 30	BRACKET, Polyester, black	1
	58-1016 40	BRACKET, Polypropylene, gray	1
	58-1016 60	BRACKET, Ryton, black	1
7	58-1316 71	O-RING, Volute, BUNA-N	1
	58-1316 72	O-RING, Volute, EPDM	1
	58-1316 73	O-RING, Volute, Viton	1
8	58-0717 71	O-RING, Screw, BUNA-N	5
	58-0717 72	O-RING, Screw, EPDM	5
	58-0717 73	O-RING, Screw, Viton	5
9	58-0715 10	SCREW, Bracket, Stainless Steel, for pumps close-coupled to engine, cast iron ped. 5/16"-24 x 1.25" long	4
	58-0715 91	SCREW, Bracket, Hastelloy C for pumps close-coupled to engine, cast iron ped. 5/16"-24 x 1.25" long	4
	58-0715 93	SCREW, Bracket, Titanium, for pumps close-coupled to engine, cast iron ped. 5/16"-24 x 1.25" long	4
	58-0728 10	SCREW, Bracket, Stainless Steel for pumps plastic pedestal mounted, close-coupled to electric, hydraulic or pneumatic motor, 5/16"-18 x 1.5" long	4
	58-0728 91	SCREW, Bracket, Hastelloy C for pumps plastic pedestal mounted, close-coupled to electric, hydraulic or pneumatic motor, 5/16"-18 x 1.5" long	4
	58-0728 93	SCREW, Bracket, Titanium for pumps plastic pedestal mounted, close-coupled to electric, hydraulic or pneumatic motor, 5/16"-18 x 1.5" long	4
11	58-0976 71	O-RING, Shaft Seal, BUNA-N	1
	58-0976 72	O-RING, Shaft Seal, EPDM	1
	58-0976 73	O-RING, Shaft Seal, Viton	1
12	58-0750 40	PLUG, Bracket Screw Protector, Polypropylene (Viton pumps only)	4
	58-0750 90	PLUG, Bracket Screw Protector, Fluoropolymer (Ryton pumps only)	4
11,13 & 14	58-0714 11	SEAL, Shaft, BUNA-N / 316SS / Carbon / Ceramic	1
	58-0714 12	SEAL, Shaft, EPDM / 316SS / Carbon / Ceramic	1
	58-0714 14	SEAL, Shaft, Viton / 316SS / Carbon / Ceramic	1
	58-0714 15	SEAL, Shaft, Hastelloy C / Teflon / Silicon Carbide	1
	58-0714 92SG	SEAL, Shaft, Non-Metallic, ECTFE, EPDM, graphite loaded silicon carbide	1
	58-0714 94SG	SEAL, Shaft, Non-Metallic, ECTFE, Viton, graphite loaded silicon carbide	1
	58-46250 11	SEAL, Shaft, 316 Stainless Steel / BUNA-N / graphite loaded silicon carbide	1
	58-46250 12	SEAL, Shaft, 316 Stainless Steel / EPDM / graphite loaded silicon carbide	1
	58-46250 13	SEAL, Shaft, 316 Stainless Steel / Viton / graphite loaded silicon carbide	1
15	58-0667 30	IMPELLER, Polyester*, 3 Vane Open, .535" Wide, 4.75" Diameter	1
	58-0704 30	IMPELLER, Polyester*, 3 Vane Open, .535" Wide, 5.5" Diameter	1
	58-0706 30	IMPELLER, Polyester*, 5 Vane Open, .535" Wide, 5.5" Diameter	1
	58-0707 30	IMPELLER, Polyester*, 5 Vane Open, .535" Wide, 5.0" Diameter	1
	58-0708 30	IMPELLER, Polyester*, 3 Vane Open, .535" Wide, 5.0" Diameter	1
	58-0709 30	IMPELLER, Polyester*, 3 Vane Open, .535" Wide, 5.25" Diameter	1
	58-0975 30	IMPELLER, Polyester*, 4 Vane Open, .975" Wide, 4.75" Diameter	1
16	58-0716 10	SCREW, Impeller, Stainless Steel, 5/16"-24 x .75" long	1
	58-0716 91	SCREW, Impeller, Hastelloy C, 5/16"-24 x .75" long	1
	58-0716 93	SCREW, Impeller, Titanium, 5/16"-24 x .75" long	1
17	58-1017 30	VOLUTE, 1-1/2" Female, 2" Male, NPT, Polyester, black	1
	58-1217 30	VOLUTE, 1-1/2" Female, 2" Male, BSP, Polyester, Black	1
	58-1018 31	VOLUTE, BUNA-N lined, 1-1/2" Female, 2" Male, NPT, Polyester, black	1
	58-1018 32	VOLUTE, EPDM lined, 1-1/2" Female, 2" Male, NPT, Polyester, black	1
	58-1017 20	VOLUTE, 1-1/2" Female, 2" Male, NPT, NORYL, gray	1
	58-1217 20	VOLUTE, 1-1/2" Female, 2" Male, BSP, NORYL, gray	1
	58-1018 21	VOLUTE, BUNA-N lined, 1-1/2" Female, 2" Male, NPT, NORYL, gray	1
	58-1018 22	VOLUTE, EPDM lined, 1-1/2" Female, 2" Male, NPT, NORYL, gray	1
	58-1017 40	VOLUTE, 1-1/2" Female, 2" Male, NPT, Polypropylene, gray	1
	58-1217 40	VOLUTE, 1-1/2" Female, 2" Male, BSP, Polypropylene, gray	1
	58-1017 60	VOLUTE, 1-1/2" Female, 2" Male, NPT, Ryton, black	1
	58-1217 60	VOLUTE, 1-1/2" Female, 2" Male, BSP, Ryton, black	1
	58-1019 20	VOLUTE, 3" Male, NPT, NORYL, gray	1
	58-1019 30	VOLUTE, 3" Male, NPT, Polyester, black	1
	58-1019 40	VOLUTE, 3" Male, NPT, Polypropylene, gray	1
	58-1019 60	VOLUTE, 3" Male, NPT, Ryton, black	1
	58-1020 31	VOLUTE, BUNA-N lined, 3" Male, NPT, Polyester, black	1
	58-1020 32	VOLUTE, EPDM lined, 3" Male NPT, Polyester, black	1
	58-1020 21	VOLUTE, BUNA-N lined, 3" Male NPT, NORYL, gray	1
	58-1020 22	VOLUTE, EPDM lined, 3" Male, NPT, NORYL, gray	1
21	58-0720 10	SCREW, Volute, Stainless Steel, 1/4"-20 x 2.375" long, for 1-1/2" / 2" pump	6
	58-1386 10	SCREW, Volute, Stainless Steel, 1-1/4"-20 x .275" long, for 3" pump	6

*NOTE: If NORYL impellers are required, change the second last digit in the part number from 3 to 2.
If Ryton impellers are required, change the second last digit in the part number from 3 to 6.
If Polypropylene impellers are required, change the second last digit in the part number from 3 to 4.

ITEM #	PART #	PART DESCRIPTION	
22	58-1009 71	O-RING, Drain Plug, BUNA-N	1
	58-1009 72	O-RING, Drain Plug, EPDM	1
	58-1009 73	O-RING, Drain Plug, Viton	1
23	58-0723 20	PLUG, Drain, NORYL, gray	1
	58-0723 30	PLUG, Drain, Polyester, black	1
	58-0723 40	PLUG, Drain, Polypropylene, gray	1
	58-0723 60	PLUG, Drain, Ryton, brown	1
27	58-0718	KEY, Steel	1
	58-0718 10	KEY, Stainless Steel	1
	58-0718 30	KEY, Molded Polyester	1
	58-0718 91	KEY, Hastelloy C	1
28	58-1238	HANDLE, Plated Steel, 3.5HP engine driven pumps only	1
29	58-0745	KEPNUT, 5/16"-18, Plated Steel	2
30	58-0778 11	SHIM, .006"	as required
	58-0778 12	SHIM, .015"	as required
	58-0778 13	SHIM, .030"	as required
31	58-1014 10	ADAPTER, Shaft, Stainless Steel, for close-coupled electric or pneumatic motor, .625 bore (see section VIB of operator's manual)	1
	58-1014 93	ADAPTER, Shaft, Titanium, for close-coupled electric or pneumatic motor, .625" bore (see section VIB of operator's manual)	1
	58-1165 10	ADAPTER, Shaft, Stainless Steel, for hydraulic motor, .563" bore	1
32	58-0883	SET SCREW, 1/4"-20 x .25" long, Steel	2
33	58-0745 10	KEPNUT, 5/16"-18, Stainless Steel	4
35	58-1011 20	PEDESTAL, Molded Plastic, Hydraulic Motor	1
36	58-0729 H	SCREW, Plated Steel, 5/16"-18 x 1.0" long, for mounting hydraulic motor to pedestal	4
38	58-1826 71	PAD, Saddle, Rubber	1
39	58-1828 90	SADDLE, Electric Motor, Molded Plastic, 6.625" Diameter	1
	58-1825 90	SADDLE, Electric Motor, Molded Plastic, 5.688" Diameter	1
40	58-1846 40	BASEPLATE, Plastic, for pumps close-coupled to electric motors	1
41	58-0934 10	STRAP, Stainless Steel, for close-coupled electric motor	1
43	58-1015 10	SCREW, Hex Head Cap, 3/8"-16 x 1.25" long, Stainless Steel	4
44	58-1010 20	ADAPTER, Motor, Molded Plastic, for pumps close-coupled to electric or pneumatic motor	1
45	58-1955 71	SEAL, Lip, BUNA-N, .710" ID	2
46	58-0882 90	SHAFT SLEEVE, Polyethylene	1
47	58-0884 71	SLINGER, BUNA-N	1
48	58-1951 90	HOUSING, Bearing, Cast Iron	1
49	58-1954 90	BEARING, Ball, .787" ID	2
50	58-1952 10	SHAFT, Stainless Steel, .75" diameter	1
	58-1952 91	SHAFT, Hastelloy C, .75" diameter	1
51	58-1953 10	PLATE, End, Stainless Steel	1
52	58-0730 10	FLAT WASHER, 5/16", Stainless Steel	2
53	58-0729 10	SCREW, Stainless Steel, 5/16"-18 x 1"	2
54	58-0745 10	KEPNUT, 5/16"-18, Stainless Steel	2
55	58-0759 20	BEARING PEDESTAL, Molded Plastic	1
56	58-0777	BEARING/SHAFT ASSEMBLY, Standard, Carbon Steel	1
	58-0777 10	BEARING/SHAFT ASSEMBLY, with Stainless Steel Shaft Sleeve	1
	58-0777 93	BEARING/SHAFT ASSEMBLY, with Titanium Shaft Sleeve	1
55 & 56	58-2053 01	ASSEMBLY, PEDESTAL, 3/4" Carbon Steel Shaft	1
	58-2053 02	ASSEMBLY, PEDESTAL, with Stainless Steel Shaft Sleeve	1
	58-2053 03	ASSEMBLY, PEDESTAL, with Titanium Shaft Sleeve	1
57	58-1956 10	SHIM, Bearing Shaft, Cast Metal Pedestal, .006" thick	as required
58	58-2525 10	SCREW, Hex, 1/4"-20 x 3/4", Stainless Steel	4
59	58-1950 01	BEARING & PEDESTAL ASSEMBLY with 3/4" Stainless Steel Shaft (includes items 45,48,49,50,51,57 & 58)	1
	58-1950 01H	SAME, with Hastelloy C Shaft	1
60	58-0686	MOTOR, Hydraulic	1
61	58-0634	ENGINE, B&S, 550 Series, recoil start	1
	58-0635 H	ENGINE, Honda, GX 160 OHV, recoil start	1
	58-0644	ENGINE, B&S, 900 Series OHV, recoil start	1
	58-0646 CP	ENGINE, B&S, 6.5 HP Vanguard OHV, recoil start	1
62	58-0926	MOTOR, Pneumatic	1
63	58-0028	BASEPLATE KIT, Std. Duty, call factory for details for flex-coupling to electric motors	1
	58-0016	BASEPLATE KIT, Heavy Duty, call factory for details for flex-coupling to electric motors	1
64	58-0933 72	GASKET, 3.5 HP Engine Protection, EPDM	1
	58-0935 72	GASKET, 5.5HP - 6.5HP Briggs OHV Engine Protection, EPDM	1
65	58-0929	BASEPLATE, Powder Coated Steel for pumps close-coupled to pneumatic motor	1

'PC' PUMP EXPLODED VIEW PARTS DIAGRAM
Figure 7

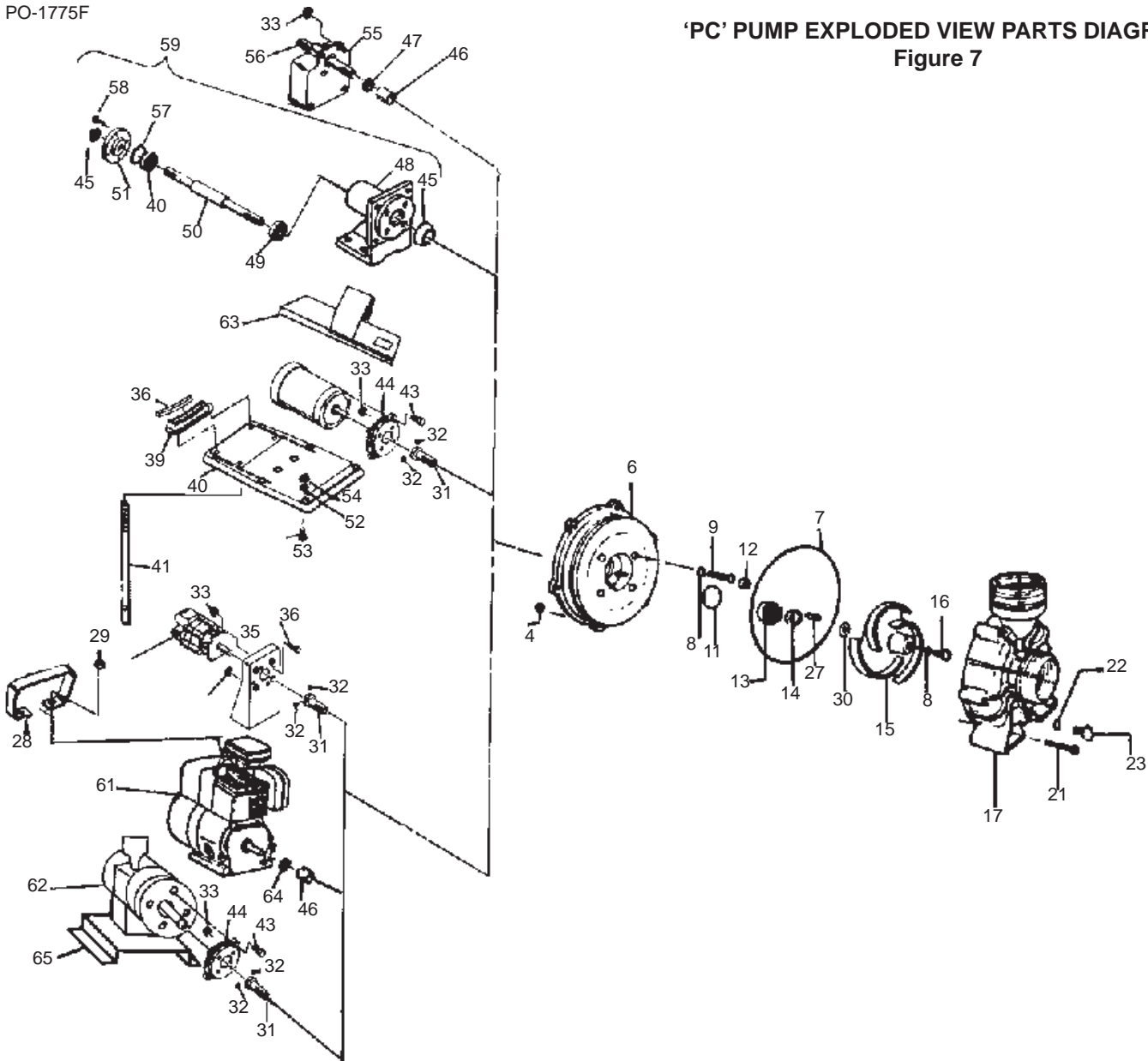

LIMITED 1 YEAR WARRANTY

Pacer Pumps warrants its products to be free from defects of material and workmanship for a period of one year (12 months) of service. If the one year of service falls within 24 months from date of manufacture. The company warrants that its products at the time of shipment, will be free of defects of material and workmanship for normal use and service. This warranty will not apply or be extended to products subject to misuse, neglect, accident, or improper installation, or to maintenance of products which have been altered or repaired by anyone except Pacer Pumps or its authorized representatives. The Buyer, or any person receiving such a product during the duration of the warranty, shall contact his Pacer Pumps dealer as soon as any defect occurs. Contact Pacer Pumps for the name and address of your nearest dealer.

Certain components, such as mechanical seals, ceramic liners, impellers, impeller magnet assemblies, pistons, hose, diaphragms, etc. may be subject to wear, and therefore, wear should not be misconstrued as to the existence of a defect and as such would not be included in a warranty claim, nor should it be implied that items such as this will last a year without occasional, or even frequent replacement depending upon the severity of the application.

Pacer Pumps obligation under the foregoing warranty shall be limited to (at its option) repair and replacement (and reship to the Buyer with transportation charges collect to anyplace in the U.S.) of defective goods provided that if the company is unable to correct a defective component part or product, the Buyer shall be entitled to elect a credit at the original buyer's purchase price. To return a

DEFECTIVE PUMP, to return any parts for credit, or to obtain service information, contact the Service Department. After receiving permission to return merchandise, the Buyer is authorized to return the product to Pacer Pumps, freight prepaid. If the company determines that the warranty has not been breached, product will be repaired or replaced free of charge.

The company will not be responsible for any damage or losses, direct or indirect, arising from any cause whatsoever, nor for damage to equipment caused by outside influences including improper installation or modification, improper voltage supply, lightning, corrosive liquids, abrasive liquids, or careless handling, nor for labor, transportation or other damages incurred in the replacement or repair of defective parts. In these cases, repair will be subject to recondition charges in effect at the time.

Purchased merchandise, either as a complete product for resale, or components used in conjunction with Pacer Pumps manufactured products, carries the warranty of the respective manufacturer of such products or components.

servicing industry worldwide
PACER® PUMPS
 Div. of ASM Industries, Inc.
 41 Industrial Circle
 Lancaster, PA 17601
 Email:sales@pacerpumps.com
 717-656-2161
 800-233-3861
 FAX: 717-656-0477

NOTE: All specifications, as shown, are subject to change without notice.

PO-1775F

'PC' PUMP EXPLODED VIEW PARTS DIAGRAM
Figure 7

