

# Operating Instructions

**HYGHSPIN**

**CHEMSPIN**

## Twin Screw Pump

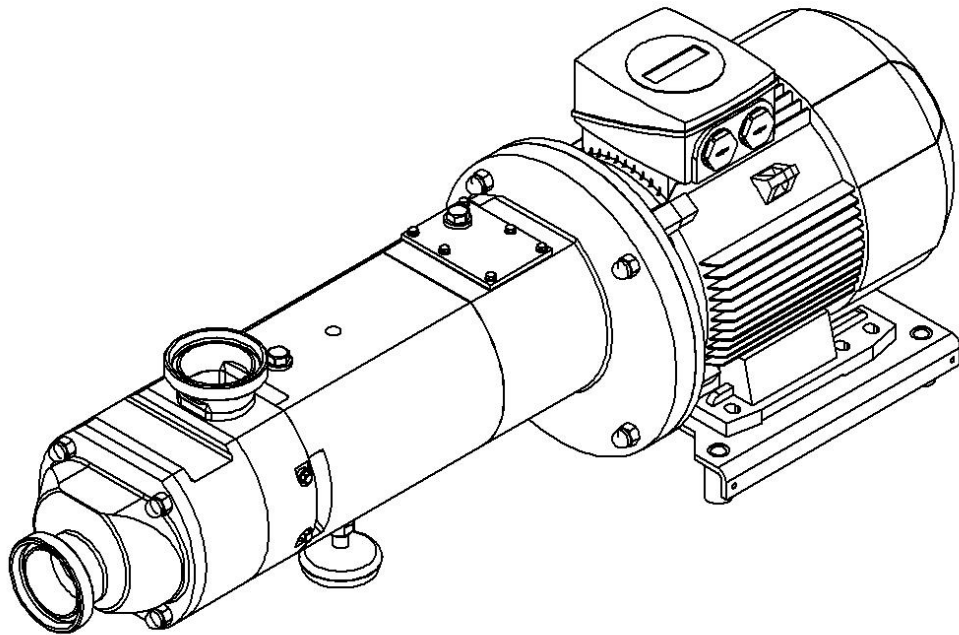

**JUNG**   
PROCESS SYSTEMS

**Jung Process Systems GmbH**  
Auweg 8 - 25495 Kummerfeld - Germany

Phone: +49 4101 80409 - 0  
Fax: +49 4101 80409 - 142  
[jung-process-systems.com](http://jung-process-systems.com)

Issue 01/2025

## Table of contents

1 General information .....	5
1.1 Notes on the operating instructions .....	5
1.2 Intended use.....	5
1.3 Scope of supply.....	5
1.4 Other applicable documents .....	6
2 Safety.....	7
2.1 Meaning of the warnings.....	7
2.2 General information .....	7
2.3 Dangers if the safety instructions are not observed .....	8
2.4 Assembly, operating and maintenance personnel.....	8
2.5 Safety devices .....	8
2.6 Conversion of the system/pump and use of spare parts .....	8
2.7 Use in potentially explosive atmospheres.....	8
3 Structure and mode of operation .....	9
3.1 Structure of the pump .....	9
3.2 Structure of the pump unit.....	9
3.3 Mode of operation of the pump .....	10
3.4 Name Plate .....	10
4 Transportation and temporary storage.....	11
5 Set-up and installation .....	12
5.1 Installation of pumps/units .....	12
5.2 Pipelines .....	12
5.3 Coupling alignment.....	14
5.4 Pumps with flushed mechanical seals.....	15
5.5 Electrical connection .....	17

6 Operation of the pump.....	17
6.1 Permissible vibrations .....	17
6.2 Commissioning .....	18
6.3 Operation.....	19
6.4 Decommissioning .....	19
6.5 Recommissioning.....	19
7 Maintenance and cleaning .....	20
7.1 Maintenance and inspection .....	20
7.2 Inspection and maintenance table.....	20
7.3 Cleaning (CIP) or sterilizing (SIP) for HYGHSPIN pumps .....	22
8 Faults / causes / elimination .....	25
9 Service, spare parts, accessories .....	25
10 Disassembly and assembly .....	26
10.2 Removing the pump from the system.....	26
10.3 Dismantling of feed screws and shaft seals.....	27
10.4 Assembly of feed screws and shaft seals .....	28
10.5 Dismantling of bearing housing.....	30
10.6 Assembly of bearing housing .....	31
10.7 Adjustment of flank clearance .....	32
10.8 Table of tightening torques .....	33
10.9 Clearances .....	33
11 Disposal .....	33
11.1 Disposal of the transport packaging.....	33
11.2 Disposal of lubricating oils and greases .....	34
11.3 Disposal of the pump or pump components.....	34
11.4 Disposal of electrical and electronic waste .....	34



## 1 General information

### 1.1 Notes on the operating instructions

These operating instructions contain basic information that must be observed during installation, operation and maintenance. It must be read by the responsible operator or owner before installation and commissioning and must always be available at the installation site, as no liability is accepted for damage or malfunctions resulting from failure to observe these operating instructions.

### 1.2 Intended use

The pump is to be used exclusively for pumping the media agreed in the order data sheet. Any other use or modification of the pump without written agreement with the manufacturer is considered as improper use.

The pump may only be put into operation once it has been ensured that all safety devices are fully installed and functional.

In potentially explosive atmospheres, only pumps with the corresponding specification in explosion-proof design may be used. There are additional operating instructions for these pumps which must be observed.

Intended use also includes compliance with the operating, maintenance and servicing requirements specified by the manufacturer.

### 1.3 Scope of supply

The pump

- can be ordered with free shaft end, i.e. delivery is without motor and without base plate

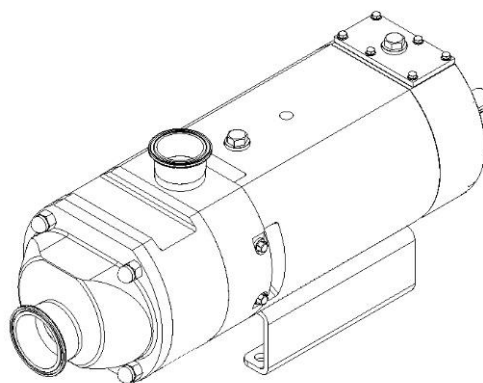

- can be ordered as a unit, i.e. fully assembled on a base plate with motor, coupling and coupling guard

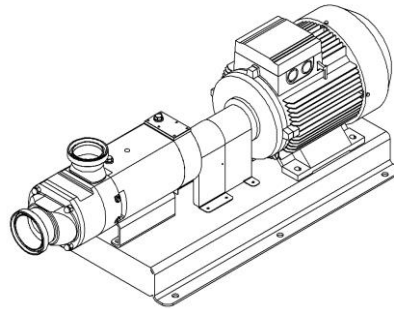

- can be ordered as a block design, i.e. pump with flange-mounted motor

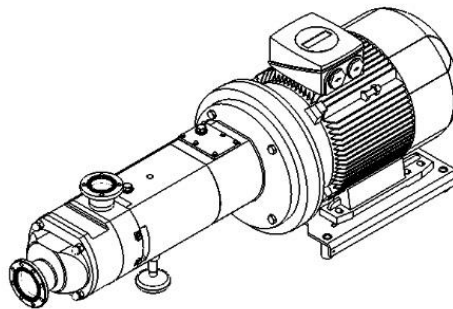

The scope of supply corresponds to the scope specified in the order. It must be checked for completeness and damage immediately upon receipt. Any damage or defects must be documented and reported to the supplier immediately.









#### 1.4 Other applicable documents

Pump data sheet	Technical data, operating conditions, performance and limits
Dimensional drawing	Designation of components, connections
Sectional drawing	Determining the positions of the parts lists
Parts lists	List of included parts
Supplementary data sheet	Technical data mechanical seal system
Supplier documentation	Technical documentation for drives and vendor parts
ATEX additional operating instructions	For pumps intended for installation in an ATEX zone
CE Declaration of Conformity	On the basis of contractual agreements or statutory provisions
Order-specific documentation	On the basis of the contractual agreements

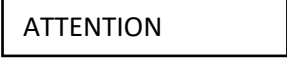
## 2 Safety

### 2.1 Meaning of the warnings

The symbols used below have the following meanings.

Signal word / symbol	Meaning
	Warns of dangers that lead to death or serious injuries if ignored
	Warns of dangers that can lead to death or serious injuries if ignored
	Warns of dangers that can lead to moderate or minor injuries if ignored
	Warns of dangers that can lead to machine damage if not observed
	<b>General danger zone</b> Indicates dangers of injury or death in connection with a signal word
	<b>Dangerous electrical voltage</b> Indicates hazards due to electrical voltages in conjunction with a signal word
	<b>Dangerous surface temperature</b> Indicates hazards from hot surfaces in conjunction with a signal word
	<b>Explosion protection</b> Provides information on protection against explosions in potentially explosive atmospheres in accordance with EU Directive 2014/34/EU (ATEX)
	<b>Machine damage</b> Indicates hazards for the machine in conjunction with the signal word CAUTION
	<b>Note</b> Gives recommendations and instructions for handling the machine

### 2.2 General information

The pump or pump unit may only be operated as intended, in a technically perfect condition, in a safety-conscious and hazard-conscious manner in compliance with these instructions and the applicable regulations.

Instructions attached to the machine must be kept complete and legible.

Any working method that endangers staff or uninvolved third parties must be avoided.

In the event of a safety-relevant fault, the pump must be shut down immediately and the fault rectified by the person responsible.

The safety regulations of the country of operation also apply.

The system must be protected against access by unqualified personnel.

### **2.3 Dangers if the safety instructions are not observed**

Failure to observe the safety instructions may endanger persons, the machine/system and the environment.

### **2.4 Assembly, operating and maintenance personnel**

Assembly, operating and maintenance personnel are persons who are responsible for the transportation, assembly, installation, operation, cleaning and troubleshooting of the pump.

The operator must ensure that all maintenance, operating and installation activities are carried out by authorized and qualified specialist personnel.

Work on the pump/unit may only be carried out when it is at a standstill. Immediately after completion of the work, all safety and protective equipment must be refitted or put back into operation. Personal protective equipment must be worn during work in accordance with the applicable regulations.

### **2.5 Safety devices**

The following safety devices must be provided and their function ensured:

- For hot, cold and moving parts that are accessible due to the installation, protection against accidental contact must be provided by the customer and must not be removed during operation
- In the event of possible electrostatic charging: provide appropriate grounding
- Suitable safety device against overpressure on the pump outlet

### **2.6 Conversion of the system/pump and use of spare parts**

Conversion or modifications to the system/pump are only permitted after consultation with the manufacturer.

For safety reasons, spare parts from the manufacturer must be used. The use of other parts excludes liability for any resulting consequences.

### **2.7 Use in potentially explosive atmospheres.**

**DANGER**



The documentation of pumps for explosive atmospheres contains additional ATEX operating instructions. These must also be observed.

## 3 Structure and mode of operation

### 3.1 Structure of the pump

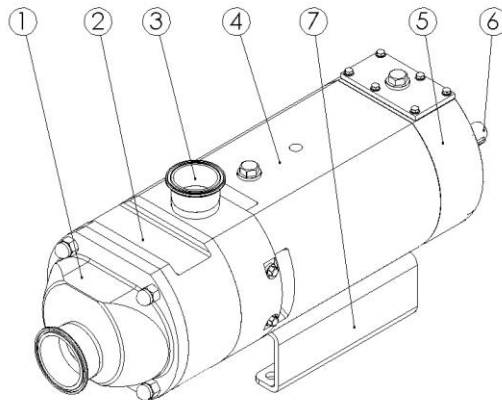

The following parts of the pump can be seen from the outside:

- 1 - Cover with connection (usually inlet)
- 2 - Pump housing
- 3 - Intermediate flange with connection (usually outlet)
- 4 - Bearing housing
- 5 - Gearbox housing
- 6 - Drive shaft
- 7 - Pump console

The drive shaft is not visible on pumps with a bloc design, as the drive is flanged directly to the gearbox housing.

Under certain conditions, it is possible to reverse the pumping direction. Please consult us for this. In this case, the outlet and inlet nozzles would be interchanged.

### 3.2 Structure of the pump unit

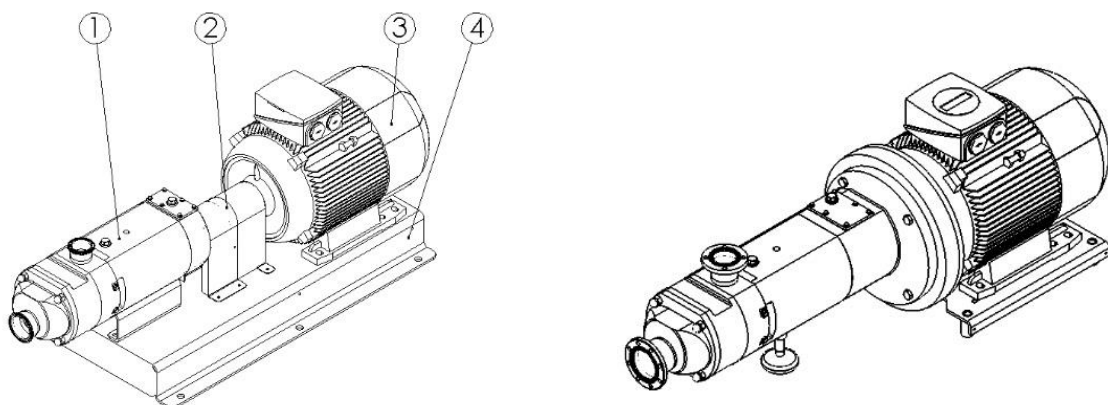

A pump unit consists of the following parts:

- 1 - Pump
- 2 - Coupling and coupling guard (not applicable for pumps in bloc design)
- 3 – Drive unit
- 4 - Baseplate

### 3.3 Mode of operation of the pump

The pumps in the HYGHSPIN and CHEMSPIN series are single-flow, twin-screw pumps with external bearings. The feed screws move the medium without contact from the inlet to the outlet of the pump. Reversible operation with limitations in the secondary direction is mostly possible. The applicable limits for the secondary direction must be agreed with us.



The product space is separated from the surroundings by shaft seals.

The following shaft seals can be used:

- Single-acting mechanical seal without flushing, dry running has to be excluded
- Double-acting mechanical seal with lost flushing alternatively circulation flushing by a quench or barrier system (see chapter 5.4).
- Single-acting lip seal without flushing

### 3.4 Name Plate

The name plate is attached to the bearing housing. Example:

		<a href="http://jung-process-systems.com">jung-process-systems.com</a>	
<u>Designation (Identification):</u> Screw pump HYGHSPIN 70-26 Bloc design			
S/N: 56541-001 Type NL		Year of construction (Date): 2024	
			
<b>Made in Germany</b>			
Product: Cream			
Pressure (Pressure) 12 bar	Speed (Speed) 1500 min <sup>-1</sup>	Temperature (Temperature) 40°C	
CIP			
Pressure (Pressure) 12 bar	Speed (Speed) 1800 min <sup>-1</sup>	Temperature (Temperature) 90 C°	

The name plate shows the maximum values of the data sheet. Higher values may be possible upon consultation.

Explanation of the designation from the data sheet:

HYGHSPIN70H-26-SA-SS-HN-NL-TS-DN80-D11851-DN50-D11851-N

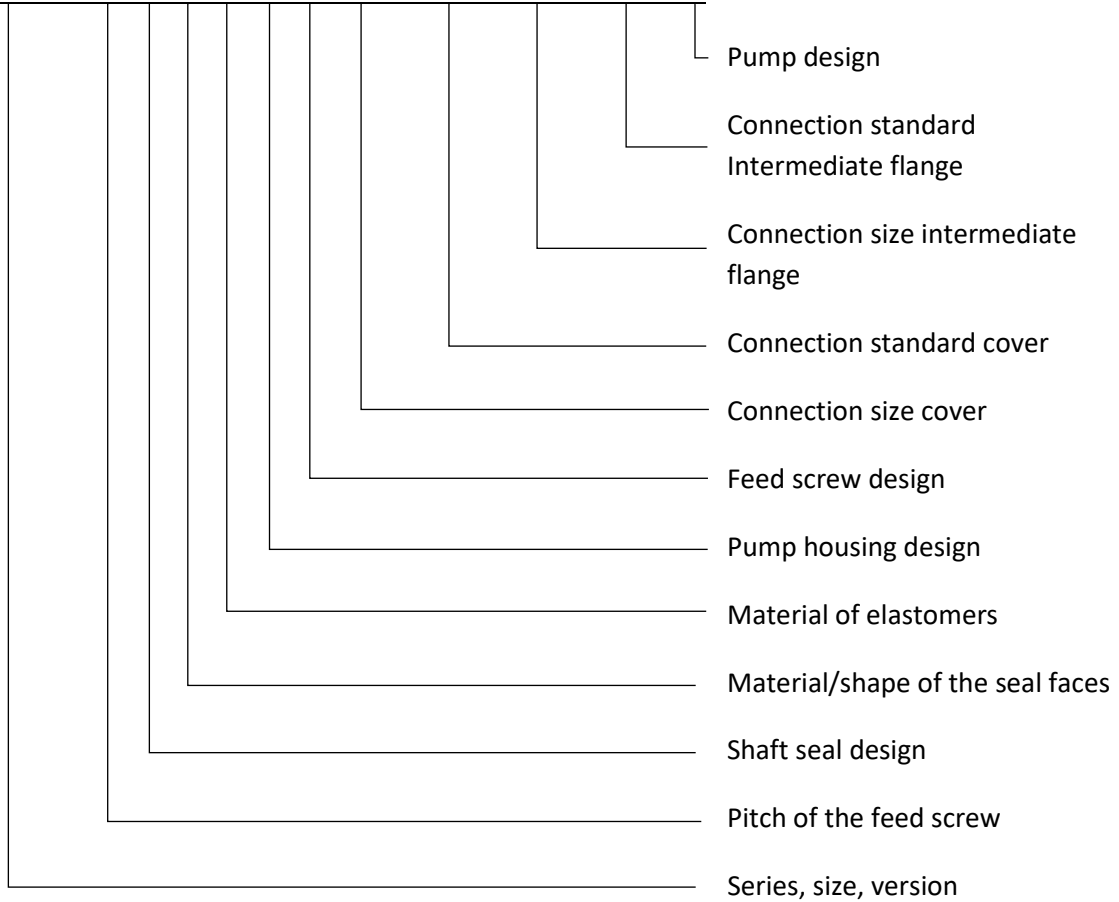

## 4 Transportation and temporary storage



There is a risk by falling or swinging parts. The pumps must be transported and secured with care to prevent damage. Lifting devices and slings must be dimensioned for the total weight of the pump or pump unit. The following illustrations show examples. The lifting points must be designed for the total weight of the unit and comply with local regulations. Lifting lugs on the pump are not included in the scope of delivery . The total weight of the unit must never be attached to the motor or the pump alone.

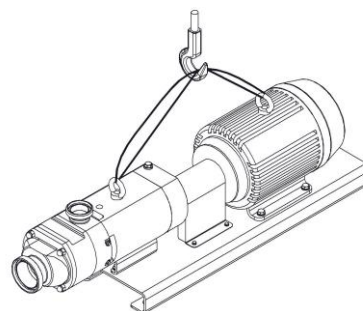
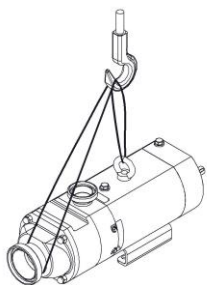

The pump may only be placed on a sufficiently firm, level surface.

ATTENTION



Improper interim storage can damage the machine or reduce its service life. Intermediate storage must be carried out in such a way that the pump is not exposed to the effects of the weather or accumulated deposits. All openings must be sealed with blind flanges, blind plugs or plastic covers.

The shafts must be rotated once a month. The keyway position must be changed.

Temperature changes that lead to condensation on and inside the pump or motor must be excluded.

## 5 Set-up and installation

DANGER



The ATEX additional instructions apply to pumps in potentially explosive atmospheres. It is advisable to check the direction of rotation before installing the motor.

### 5.1 Installation of pumps/units

WARNING



The foundation or floor must be suitable for the load. Otherwise there is a risk of personal injury or damage to the machine. The height deviation of the foundation must not exceed 0.33 % of the length (1 cm height per 300 cm length).

Sufficient space must be provided for maintenance, installation and heat dissipation from motor.

If no foundation is available, leveling feet must be used. For pumps/units with 3A certification, a clearance of at least 100 mm from the floor must be maintained. Machine feet certified to 3A must be used for this purpose.

### 5.2 Pipelines

DANGER



Leaks due to improper connection can lead to personal injury. The pipelines must be laid as stress-free and pressure-tight as possible. They must be installed in such a way that as few forces, moments and torques as possible are transferred to the pump via the connections. Changes of the piping length caused by temperature changes must be taken into account and compensated for as far as possible by suitable measures in order to prevent overload on the pump.

The maximum loads of the pump connections are as follows:

Nominal diameter [mm]	F <sub>(x,y,z) max.</sub> [N]	F <sub>(total) max.</sub> [N]	M <sub>(x,y,z) max.</sub> [Nm]	M <sub>(total) max</sub> [Nm]
25	190	270	85	125
40	255	360	115	170
50	295	420	145	210
80	425	600	215	315
100	505	720	260	385
125	610	870	325	480
150	720	2020	385	565
200	930	1320	500	735

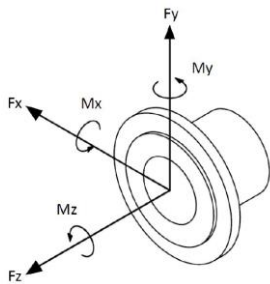

$$F_{total} = \sqrt{F_x^2 + F_y^2 + F_z^2} \quad M_{total} = \sqrt{M_x^2 + M_y^2 + M_z^2}$$

The maximum values should not be reached for all individual forces and torques at the same time. For diameters between the specified values, the values for the next smaller nominal diameter must be selected.

Maximum loads of the following diameters are provided for the individual pump sizes.

Pump size	Nominal diameter [mm]
50	50
70	80
90	100
105	100
125	200

To avoid the formation of air pockets, the inlet line to the pump must be routed continuously rising or continuously falling. The inlet line must be dimensioned according to the application.

**ATTENTION**



Cavitation leads to machine damage. It must therefore be ensured that no cavitation can occur. For this purpose, the NPSH value on the system side must be calculated and it must be ensured that this does not exceed the required NPSH value of the pump at the individual operating points. A safety margin should be considered. We recommend a safety distance of 0.5 m.

The achievable flow velocities towards the pump depend on the viscosity of the product, the properties and the application. The following table shows guide values, but these must be checked in each individual case:

Product viscosity [mPas]	Pump inlet speed [m/s]
1	< 2,5
100	< 1,5
1000	< 1
10000	< 0,6
50000	< 0,3

We generally recommend not exceeding 1.5 m/s for production operation.

Venting options must be provided on the suction and discharge sides.

Sudden changes in cross-section and direction in the piping system must be avoided.

Transition pieces to larger diameters should be designed with an expansion angle of approx. 8° to avoid increased pressure losses.

ATTENTION



Before commissioning, tanks, pipes and connections must be thoroughly cleaned to remove any remaining welding beads, scale and other impurities. Foreign particles must not get into the pump under any circumstances. We recommend to disconnect the pump from the system during the flushing process.

DANGER



Suitable measures must be taken to ensure that the product does not cause an autorotation of the pump by flowing back after pump switch off.

### 5.3 Coupling alignment

DANGER



Incorrect alignment can result in explosions.

WARNING



Before aligning, the pumps must be disconnected and secured against being switched on.

ATTENTION



Misalignment of the pump and drive shafts leads to increased wear of the bearings, mechanical seals, other shaft seals and the flexible elements of the coupling and causes the unit to run with increased vibrations. Couplings must therefore be aligned. Before commissioning of a pump, the alignment must be checked at site, as changes may occur during transportation and installation in the system.

Procedure for pumps with free shaft end:

- Align the pump using a spirit level on the drive shaft and on the radial connection piece, place feather keys when installing the coupling and push on the coupling halves without tilting, do not impact or knock the pump and motor components.
- Fix the coupling parts on the shafts
- Align the motor precisely towards the pump in accordance with the coupling manufacturer's specifications
- Fit the coupling guard. When using a protective motor cover, ensure that there is enough space to ventilate the unit
- For higher operating temperatures, a supplementary alignment at operating temperature is required

For bloc design pump units, the pump and motor shaft are centered towards by geometry. In this case, only the axial distance between the coupling halves needs to be ensured

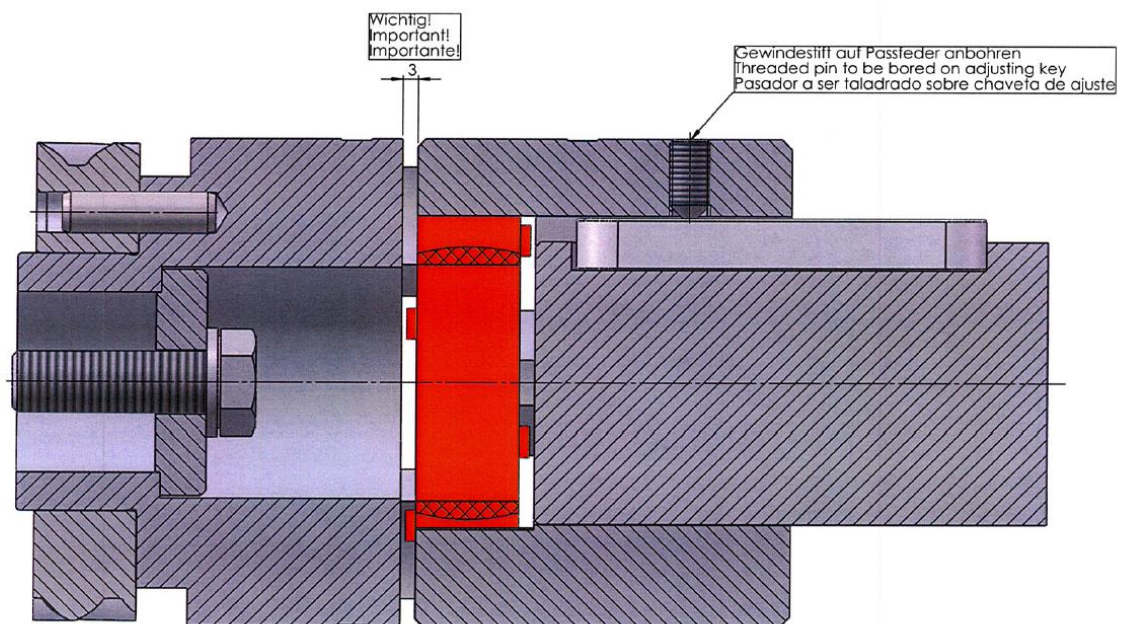

## 5.4 Pumps with flushed mechanical seals

In a pump with flushing, the sliding surfaces of the mechanical seal are additionally lubricated and cooled with an external fluid.



A faulty connection can result in explosions in potentially explosive atmospheres.

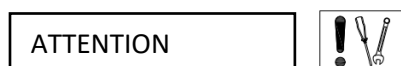

Otherwise there is a risk of machine damage. As the flushing chambers of the mechanical seals are usually not connected to each other, each side of these pumps must be connected separately. The dimensional drawing of the pump must be observed.

The flushing medium always enters from below to ensure complete venting. Each seal and the supply lines must be vented.

For trouble-free operation, a flow rate through the seal (0.5 to 1 liter/minute) is optimal. The maximum flushing pressure is 5 bar. In the case of a lost flushing, a connection in line of the mechanical seals should be selected:

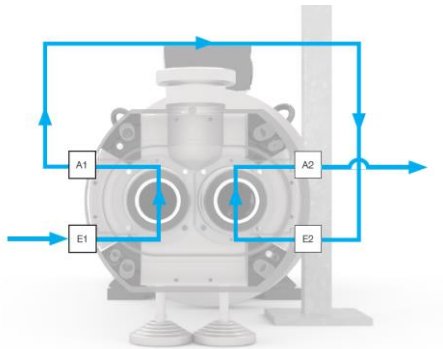

- Entry E1 bottom left
- Exit A1 top left
- Entry E2 bottom right
- Exit A2 top right.

When using a buffer tank with natural circulation or circulation pump, two separate lines to each mechanical seal or a split above the pump are required. The flushing chambers must be connected in parallel. The inlet is from below.

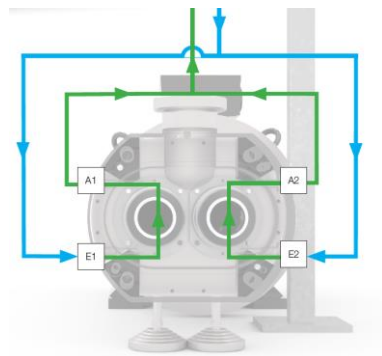

- Entry E1 bottom left
- Exit A1 top left
- Entry E2 bottom right
- Exit A2 top right.

The pipe cross-section should be at least as large as at the flushing connections of the pump. The buffer tank should be installed as high as possible (at least 1.5 m above the pump) in order to utilize the differences in gravity of the liquid column.

When filling the tank, it is essential to vent the pipe.

- Disconnect return lines individually at the supply tank or before merging
- Liquid is filled in until it flows out of the separation points
- Closing the disconnected points in the lines

The standard supply tank (quench) is open to atmosphere. However, it is also possible to use buffer tank systems, with a pressurisation of less than 5 bar.

Low-viscos liquids (less than 10 mm<sup>2</sup>/s) should be used as flushing liquid. Consultation is required for higher viscosities. Forced circulation of the flushing or buffer liquid may be necessary.

## 5.5 Electrical connection

**DANGER**



The electrical connection must be carried out by a qualified electrician. The relevant regulations must be observed. Before working on the electrical system, the system must be disconnected from the power supply and secured against being switched on.

**DANGER**



A faulty connection can result in explosions in potentially explosive atmospheres.

**ATTENTION**



The operating instructions for the motor must be observed. Connect the motor according to the wiring diagram with suitable cable glands and cable cross-sections.

The connecting cables must be protected. To prevent overheating, connect the PTC thermistors of the motors and provide motor protection switches if necessary.

**ATTENTION**



If other motors than those supplied are used, the operator is responsible for their safety and function. For pumps in block design, ensure that the motor is suitable for connection to the pump gearbox. The motor flange and the shaft seal of the drive must be oil-tight.

The correct direction of rotation of the pump must be ensured.

## 6 Operation of the pump

### 6.1 Permissible vibrations

**DANGER**



Excessive vibrations can cause explosions in potentially explosive atmospheres.

**ATTENTION**



Unacceptably high vibrations cause a shortened service life or even failure of the pump. Other elements in the system may also be affected. Vibrations indicate a faulty pump or faulty operation. They must therefore be recorded when a pump is commissioned and subsequently at regular intervals. The limit values are determined in accordance with ISO10816-7, taking into account our own operating experience.

Zone	Description of the zone	Vibration velocity, effective value [mm/s]
A	Newly commissioned machine in the preferred range of operation	< 2,5
B	Unrestricted continuous operation within the permissible operating range	< 4,0
C	Limited continuation of operation, risk of machine damage	< 6,6
D	Immediate risk of machine damage	> 6,6
	Maximum ALARM limit	5,0
	Maximum SWITCH-OFF limit	6,6

The vibrations (1 to 6) at the bearing points are decisive.

Vibrations at the pump housing and cover (7 + 8) are to be included for information purposes.

If increased vibrations are detected, the cause must be investigated and eliminated. These are often caused by the operating mode or the system.

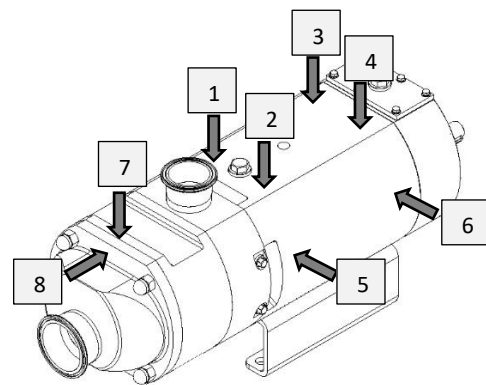

## 6.2 Commissioning

The pump can only run dry with suitable shaft seals and under certain operating conditions. The occurrence of dry-running phases must therefore be avoided or agreed with the manufacturer in advance. The pump should only be put into operation when filled with pumped liquid.

Measures must be taken (e.g. safety valve) to protect the pump from impermissible overpressure. Contact guards for hot, cold and moving parts must not be removed during operation.

ATTENTION



Commissioning without sufficient lubrication of the bearings and/or mechanical seals can lead to machine damage.

DANGER



Incorrect commissioning can result in explosions in potentially explosive atmospheres.

- Check the oil level on the bearing housing and fill up if necessary
- Prepare auxiliary operating systems, if applicable
- Check flushing system, observe manufacturer's additional instructions if available
- Connect the heating system, if available
- Connect the cooling system, if available

- Clean or sterilize the pump if necessary
- Open valves in the suction and pressure line
- Fill the pump with pumped liquid and visually check for leaks
- Vent pipes
- Switch on motor, check the sense of rotation and pumping direction, set operating speed
- After reaching the operating data, visually check the pump for leaks. Inspect the operating behaviour according to the inspection and maintenance table (see 7.2)

### 6.3 Operation

ATTENTION



The pump should always be operated quietly and without shocks. The following conditions must be observed to ensure trouble-free operation:

- Dry running must be avoided
- Do not allow cavitation - always keep shut-off devices in the suction line open during operation
- Ensure that the pump is tight
- Ensuring the functionality of the auxiliary systems

### 6.4 Decommissioning

ATTENTION



An incorrect procedure can lead to damage to the machine

- Switch off the motor or shut it down
- Observe the situation, the stoppage should be smooth
- If present, maintain the following functions:
  - for barred double mechanical seals: buffer pressure until pump is depressurized
  - for flushed double mechanical seals: Flushing supply until standstill
  - Cooling water supply until operating temperature of the pump < 100 °C
- Close suction-side and pressure-side valves during longer downtimes
- If available, switch off the heating
- If necessary, clean or sterilize the pump

### 6.5 Recommissioning

ATTENTION



Before recommissioning after a fault, the cause of the fault must be evaluated and eliminated. Assure that the pump can be rotated smoothly to prevent consequential damage.

DANGER



Missing elimination of failure causes can result in explosions in potentially explosive atmospheres.

## 7 Maintenance and cleaning

**DANGER**



During maintenance, inspection and repair work, the system must be disconnected from the power supply and secured against being switched on. The following risks exist:

- Injuries caused by rotating parts
- Burning due to hot surfaces
- Electric shock due to static charge, grounding must be ensured
- Danger from corrosive, toxic or explosive media

### 7.1 Maintenance and inspection

**ATTENTION**



Regular maintenance and inspection is the basis for safe and trouble-free operation.

### 7.2 Inspection and maintenance table

Inspection interval	Assembly group	Maintenance measure
During commissioning	Complete unit	Document vibrations on the bearing and pump housing, contact us in case of increased values
Hourly during the start phase	Complete unit	Pay attention to changes of the noise or vibration level
Hourly during the start phase	Buffer or quench system	Check the fill level of the quench or buffer tank, correct if necessary
Daily	Complete unit	Pay attention to changes in the noise or vibration level
Daily	Gear housing	Check oil level, fill up if necessary
Daily	Mechanical seal, housing seals, radial sealing ring	Check for leaks, if leaks are present, coordinate with the manufacturer or replace
Daily	Buffer or quench system	Check function, refill if necessary. If contaminated, check mechanical seals and replace buffer or quench fluid
Daily	Heating or cooling	Check for function and tightness
Weekly	Bearing housing	Temperature control, alarm: 110°C, switch-off: 120°C
For the first time after 300 h of operation or after 3 months	Gear housing	Change gear oil
Subsequently every 3000 h of operation or after 6 months in the case of non-continuous operation *	Gear housing	Change gear oil

Inspection interval	Assembly group	Maintenance measure
Every 6 months	Buffer system	Change buffer liquid
Every 6 months	Complete unit	Document vibrations on the bearing and on the pump housing, compare values with initial and permissible values, contact us in case of increased values
Following every 15000 h of operation or after 3 years	Bearings	Preventive replacement for pumps in potentially explosive atmospheres (ATEX -zones)
Following every 20000 h of operation or after 5 years	Bearings	Preventive replacement recommended for pumps with differential pressures > 20 bar and speeds > 1500 min <sup>-1</sup>
Following every 30000 h of operation or after 7 years	Bearings	Preventive replacement recommended
Every 6 months	Coupling elastomers, Radial sealing rings	Check condition, replace if necessary
Every 12 months	Coupling elastomers, Radial sealing rings	Preventive replacement for pumps in potentially explosive atmospheres (ATEX -zones)
Every 12 months	Mechanical seals	Check the condition for pumps in in potentially explosive atmospheres (ATEX -zones)

\* The oil change intervals can be extended if the oil conditions have been analyzed by a specialist laboratory on the basis of the existing operating conditions.

For maintenance and inspection of the drives or accessory components, please refer to the manufacturer's operating instructions.

### 7.2.1 Change of gear oil

**WARNING**



Work should be carried out on the warm bearing housing (min. 40°C) in order to ensure proper oil drainage.

- Unscrew the drain plug on the gear housing and drain the lubricating oil
- Remount the drain plug back in with a new seal
- Remove the inspection cover on the gear housing and fill up with oil until the oil level reaches the middle of the oil level gauge
- Refit the inspection cover on the gear housing

The following gear oils are suitable for the food and pharmaceutical sectors:

- Gear oil with NSF or USDA H1 approval, synthetic oil based on polyalphaolefin, don't mix with mineral oils

**ATTENTION**



Material damage is caused by using different lubricants that are incompatible with each other! Use only one type of lubricant. Do not mix lubricants.

### 7.2.2 Lubricant table

The oil used at the factory for lubricating the bearings and the gear is Addinol Foodproof XHF 150 S. Other oils can be used in accordance with the above specifications after consultation. An approval by us is required on the case. Examples are listed below:

Manufacturer	Gear oil
Aral/Castrol/Opti	Optileb GT100
Esso	see Mobile
Fox/DEA	Geralyn SF100
Klüber	Klüberoil 4 UH1-100N
Mobile	MOBILE DTE FM100
Bremer & Leguil	Cassida Fluid HF100

The following lubricant quantities are required per pump

Pump size	with free shaft end [l]	Bloc design [l]
50	-	1,5
70	1,5	2,0
90	2,0	4,0
105	2,3	5,5
125	3,5	8,0

For horizontal pumps the oil is filled up to the middle of the oil level sight glass when pumps are at a standstill. The oil quantities for the block design pumps are influenced by the motor size and the motor supplier. The maximum values are specified. Higher values are required for vertical pumps.

### 7.3 Cleaning (CIP) or sterilizing (SIP) for HYGHSPIN pumps

**WARNING**



During these processes high temperatures occur on the surfaces. With some exceptions, the pumps are self-draining. For safe cleaning, an inlet velocity of 1.5 m/s or more is recommended.

#### 7.3.1 CIP cleaning at CIP temperature < 90 °C

**ATTENTION**



Pumps can either operate as CIP pumps or only run in parallel. In the case of an external CIP system, it must be ensured that the CIP volume flow supplied to the pump does not exceed the displacement of the pump at the set speed. Otherwise there is a risk of damage. It must also be ensured that the pump does not cavitate.

- The pump is switched off
- Put the buffer or flushing system into operation for pumps with flushed mechanical seals
- Switch the piping system to CIP medium
- Start the pump
- Clean the piping system and the pump
- Switch off the pump
- Remove CIP medium completely
- If necessary, flush and neutralize the system

### **7.3.2 Sterilization (SIP) with steam < 145 °C, pumps with double-acting mechanical seal or lip seal**

- The pump is switched off
- For pumps with flushed shaft seals, put the buffer or flushing system into operation, ensure sufficient flushing flow to prevent vaporization in the flushing chamber
- Switch the piping system to SIP medium
- Start the pump
- Clean the piping system and the pump
- Switch off the pump
- Remove the SIP medium completely
- If necessary, flush and neutralize the system

### **7.3.3 Sterilization (SIP) with steam <145°C, pumps with single mechanical seal**

- The pump is switched off
- Only clean/sterilize the pump when it is at a standstill, the pump must be blocked as the shaft seals can run dry due to a turbine effect
- Switch the piping system to SIP medium
- Clean the piping system and the pump
- Remove the SIP medium completely
- Release blockage
- If necessary, flush and neutralize the system

### **7.3.4 Sterilization (SIP) with hot water < 145 °C**

ATTENTION



Pumps can either operate as SIP pumps or only run in parallel. In the case of an external supply, it must be ensured that the SIP volume flow supplied to the pump does not exceed the displacement of the pump at the set speed. Otherwise there is a risk of damage. It must also be ensured that the pump does not cavitate.

- The pump is switched off
- For pumps with flushed shaft seals, put the buffer or flushing system into operation, ensure sufficient flushing flow to prevent vaporization in the flushing chamber
- Switch the piping system to SIP medium

- Start the pump
- Clean the piping system and the pump
- Switch off the pump
- Remove the SIP medium completely
- If necessary, flush and neutralize the system

### 7.3.5 Mechanical cleaning or sterilization

**DANGER**



When working on the pump, the system must be disconnected from the power supply and secured against being switched on. The following risks exist:

- Injuries caused by rotating parts
- Burns from hot surfaces
- Electric shock due to static charge, grounding must be ensured
- Danger from corrosive, toxic or explosive media

Procedure:

- Switch off the pump, secure against restarting
- Close suction and pressure-side valves
- Switch off heating or cooling, if present, and secure against restarting
- Switch off auxiliary operating systems, if present, and secure against restarting
- Depressurize pump and auxiliary operating systems
- Detach the suction and discharge line from the pump housing
- Remove the cover and pull off the pump housing
- Remove the fastening bolt
- Remove the formrings on the intermediate flange and cover
- Clean/sterilize the pump housing, feed screws, tensions nuts and stud bolts with a suitable cleaning agent
- Insert formrings
- Mount the fastening bolt
- Slide the pump housing over the feed screws and fasten the housing via the cover. Ensure that the housing is positioned correctly (see 10.4)

### 7.3.6 Cleaning the outer surfaces

**ATTENTION**



- Switch off the pump, secure against restarting
- Cover the drive or protect it from cleaning fluid
- Avoid cleaning jets against mechanical seals, radial sealing rings, venting devices and cable glands

## 8 Faults / causes / elimination

No flow rate	Flow rate too low	flow rate too high	Pump does not prime	Unstable operation	Pump cannot be rotated	Pump has leakage	Power consumption of the motor too high	Impermissible temperature increase	Cause	Elimination
x	x			x			x	x	Pressure difference too high	Adapt operating data
x	x		x					x	Clearances between feed screws and housing too large	Replace worn parts
x			x						Wrong sense of rotation	Change sense of rotation
x	x		x					x	Speed too low	Increase speed
x	x		x	x					Inlet pipe closed	Open the supply line (valve)
x	x		x						Air is sucked in	Seal the inlet, Increase speed
x	x		x	x					Pump cavitates: NPSHr < NPSHa	Optimize supply line, Reduce speed
x			x	x			x	x	Pressure line closed	Open pressure line
x			x		x		x		Pump blocked by solids	Clean the pump, coordinate with the manufacturer
x	x	x	x	x			x	x	Operating conditions deviate from data sheet	Coordinate with the manufacturer
		x		x			x	x	Speed too high	Reduce speed
x	x		x			x			Faulty shaft seal	Replace shaft seal
x			x						Pump not filled before starting	Fill up the pump
				x			x	x	Oil level in gear housing too low	Adjust oil level, replace roller bearings as a preventive measure
			x			x			Housing forming defective	Replace forming
				x	x		x		Pipe and pump braced	Optimize piping
				x	x		x		Clearances bridged by coverings	Clean feed screws and pump housing
				x	x				Coupling not aligned	Align the coupling
				x	x		x		Thermal expansion of the pumping elements due to rapid temperature fluctuations	Wait for the temperature balance
					x		x	x	Roller bearing faulty	Replacing roller bearings

## 9 Service, spare parts, accessories

Spare parts not supplied by the manufacturer are not approved. The installation and/or use of such parts can change the characteristics of the pump and thus impair safety.

Any liability and warranty is excluded for damage caused by the use of third-party parts and accessories. Faults that cannot be rectified by the user should only be rectified by the manufacturer's service department or an authorized third-party.

Spare parts can be requested directly. The drawings supplied are only used to allocate the spare parts in the corresponding parts list. They must not be understood as assembly instructions.

## 10 Disassembly and assembly

### 10.1 General

These instructions must be used in conjunction with the sectional drawing. For reasons of economy and operational safety, the following parts must be replaced after each disassembly:

- Flat sealings (items 128, 201, 210)
- Radial sealing and gamma rings (items 105, 106)
- Lock washers (item 109)
- Spring washers (items 113, 114)

The elastomers or lips on the shaft seals (item 104) and the formrings (items 103, 126) can be replaced upon requirement. After prolonged operation (> 12 months), we recommend a preventive replacement.

The material and product compatibility of all auxiliary materials used: lubricants, lubricants, cleaning agents, adhesives and securing agents, must be checked before use.

**DANGER**



When working in potentially explosive atmospheres, it must be ensured that no flammable atmosphere is present, or it must be ensured that no sparks that could cause ignition are produced by the use of suitable tools.

### 10.2 Removing the pump from the system

**DANGER**



When working on the pump/unit, the system must be disconnected from the power supply and secured against being switched on. The following risks exist:

- Injuries caused by rotating parts
- Burns from hot surfaces
- Electric shock due to static charge, grounding must be ensured
- Danger from corrosive, toxic or explosive media.

***Attention: Observe the safety chapter in the operating instructions!***

- Dismantle the piping on the pressure and suction side
- Remove the coupling guard
- Detach the pump-side coupling part from the drive shaft and pull the coupling apart
- Secure the pump with suitable lifting device on the crane or on a suitable lift truck
- Remove the pump foot from the base plate. Caution: Danger of tipping!
- Lift the pump and place it on a suitable surface
- Remove lifting device

### 10.3 Dismantling of feed screws and shaft seals

- Remove cap nuts (item 100), pull off cover (item 1) and pump housing (item 2)
- Remove the formrings (item 103)
- Use a soft piece of metal (aluminum) to block the feed screws via the gear wheels (items 11 and 13) on the gearbox. The inspection opening of the gearbox (item 30) should be opened for this purpose. The gear housing (item 5) does not need to be removed

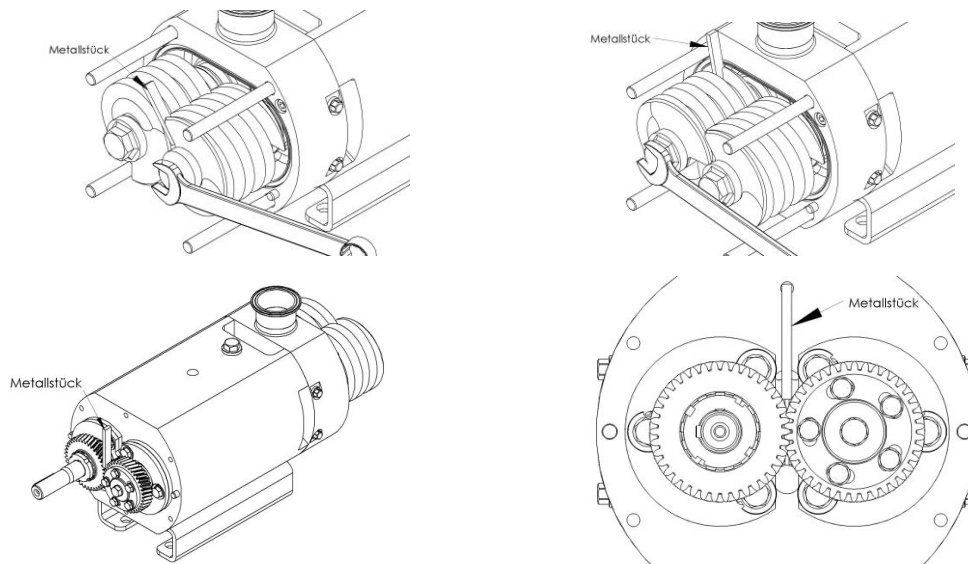

- Alternatively, blocking with the aid of a soft piece of metal (aluminum) directly on the feed screws is possible. However, there is a certain risk of damage. Blocking via the gear wheels is therefore recommended
- Loosen the clamping nuts (item 18) counterclockwise
- Remove the lower stud bolts (item 9)
- Check whether the tooth position of the feed screws in relation to the shaft is marked. If not, a marking must be provided
- Remove the pair of feed screws (item 6)
- If a mechanical seal (pos. 104) is installed, remove the inner rotors.

NOTE



For mechanical seals it is important that the faces remain assigned. Surfaces must not be interchanged. This can lead to leaks even if the seals are intact

- Remove cylindrical bolts (item 102)
- Remove intermediate flange (item 3), guide with upper stud bolts (item 9)
- Remove the upper stud bolts (item 9)
- For double-acting mechanical seals (item 104), remove the outer rotors from the shafts
- Remove the cylindrical bolts for the mechanical seals on the intermediate flange (item 3)
- Remove the static unit of the shaft seals (item 104) from the intermediate flange (item 3), insert the jacking screws on the flange of the shaft seal if necessary

## 10.4 Assembly of feed screws and shaft seals

### *For tightening torques refer to table 10.8*

- If a mechanical seal is installed, check the seal faces for scoring and flaking and the elastomers and springs for defects. Surfaces of mechanical seals must be thoroughly cleaned before installation.
- Insert the static unit of the shaft seal (item 104) into the intermediate flange (item 3) and fasten it to the intermediate flange (item 3) using cylindrical bolts.

NOTE



Lubricate the outer fromrings with a suitable grease or oil to prevent damage during insertion. Spare mechanical seals contain this lubricant.

- For double-acting mechanical seals, mount the outer rotors on shafts
- Mount 2 stud bolts (item 9) to guide the intermediate flange (do not screw in all the way)
- Insert the formring (item 103)
- Mount the intermediate flange (item 3) and fasten it with cylindrical bolts (item 102)
- Remove the stud bolts (item 9) again
- Mount the inner rotors of the mechanical seals, check that the mechanical seal can be compressed freely
- Place the feed screws on a flat surface so that they interlock and turn them against each other until both end faces are in full contact with the surface

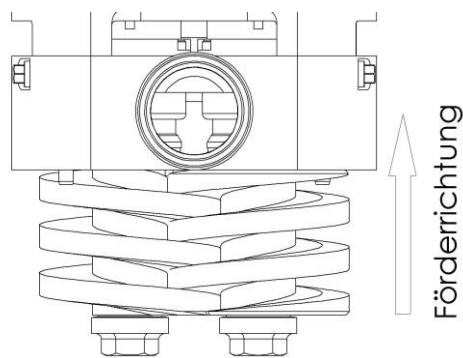

**Type NR**

Feed screws positions for clw. motor rotation  
(view on motor cooling fan towards the pump)  
Shaft seal on the pressure side, designation "VS" on  
the bottom of the pump housing

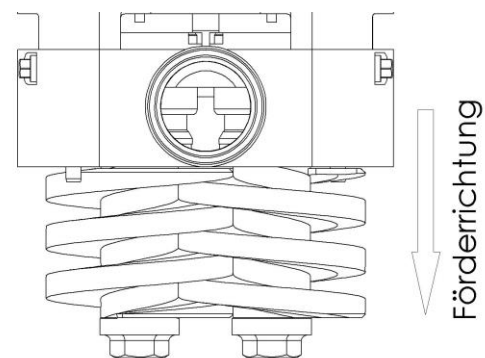

**Type SR**

Feed screws positions for clw. motor rotation  
(view on motor cooling fan towards the pump)  
Shaft seal on the suction side, designation "VS"  
on the bottom of the pump housing

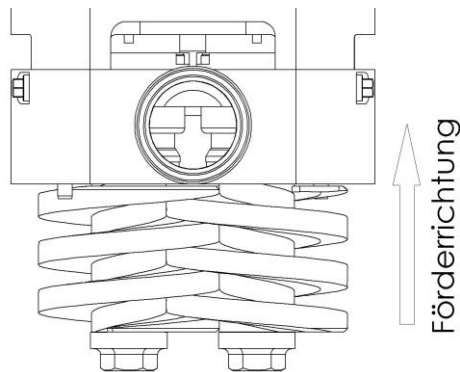

**Type NL**

Feed screws positions for cclw. motor rotation  
(view on motor cooling fan towards the pump)  
Shaft seal on the pressure side, designation "VS" on  
the top of the pump housing

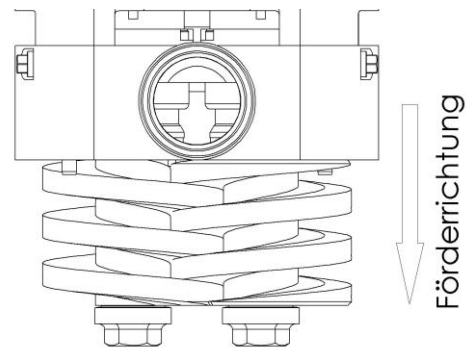

**Type SL**

Feed screws positions for cclw. motor rotation  
(view on motor cooling fan towards the pump)  
the pump), shaft seal on the suction side,  
designation "VS" on the top of the pump housing

NOTE



**The feed screws must not be interchanged, otherwise the pumping direction of the pump will change. The installation type (NR, SR, SL or NL) can be found on the name plate of the pump.**

- Place the feed screws on the shafts. If used parts are reassembled, observe the markings on the shafts and feed screws

ATTENTION



These are not available on new parts. The flank tolerance must always be adjusted

- Block the feed screws using a soft piece of metal (aluminum). This can be done on the feed screws themselves or via the gear wheels (items 11 and 13) on the gearbox. The inspection opening of the gearbox (item 30) must be opened for this purpose. The gearbox housing (item 5) does not need to be dismantled (see chapter 10.3)
- Tighten the feed screws (item. 6) clockwise with the tension nuts (pos. 18) (observe the tightening torques). The tension nuts must be secured with a suitable screw adhesive
- Adjust the flank tolerance - see chapter 10.7
- Mount the stud bolts (item 9) (do not screw in completely)
- Mount the pump housing (item 2). The "VS" stamped on one face must be positioned towards the intermediate flange in accordance with the type designation (NR, SR, NL or SL)

ATTENTION



**Observe the installation position!**

Incorrect installation can lead to a metal contact and consequential damage

**DANGER**



In potentially explosive atmospheres, the resulting damage can lead to explosions

- Insert the formring (item 103) into the cover
- Mount the cover (item 1)
- Assemble cap nuts (item 100) with washers (item 101) and tighten (observe tightening torques)

### 10.5 Dismantling of bearing housing

- Dismantling the product side, see chapter 10.3
- Drain the gear oil via the oil drain plug (item 19)
- Remove cylindrical bolts (item 122)
- Pull off the gear housing (item 5), remove the flat gasket (item 128)
- Block the gear wheels (items 11 and 13) using a soft piece of metal (aluminum)

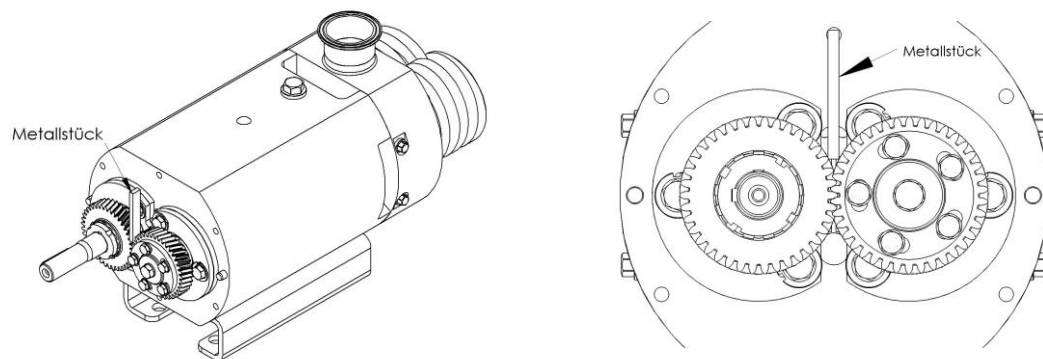

- Loosen hexagon bolts (item 112) and remove them with washers (item 111)
- Loosen hexagon bolts (item 115)
- Pull off the gear wheel (item 11) with tensioning disk (item 12) and tensioning bushing (item 10)
- Loosen hexagon bolt (item 115)
- Pull off gear wheel (item 13) with clamping disk (item 12) and with coupling (item 300) for block design
- Remove bearing cover (items 14 and 15) with NILOS ring (item 121)
- Pull off spacer for gear wheel (item 16)
- Pull the shafts (item 7) out of the bearing housing (item 4)
- Remove the front locking V-ring (item 125)
- Move the conical spacer (item 17)
- Remove the angular ball bearing (item 107) using a puller
- Pull off the conical spacer (item 17)
- Remove rear retaining V-rings (item 125)
- Remove needle bearing (item 123)
- Remove the radial sealing ring (item 106)

## 10.6 Assembly of bearing housing

### *For tightening torques refer to table 10.8*

- Fit one retaining V-ring (item 125) on each shaft (item 7)
- Heat up bearings to 120° C with a suitable device before mounting

NOTE



The bearing temperature must NOT exceed 140° C, even partially!

- Mount inner bearing ring and needle bearing (item 123) onto shafts (item 7)
- Place rear retaining V-rings (item 125) on shafts (item 7)
- Mount the conical spacer (item 17) with the larger diameter towards the needle bearings, note the installation position
- Mount the angular ball bearings (item 107) on the shafts

ATTENTION



#### **Observe the installation position**

Incorrect installation of the angular contact bearings (pos. 107) and the conical spacer (item 17) can lead to premature bearing and consequential damage.

DANGER



In potentially explosive atmospheres, bearings damages or consequential damages can lead to explosions.

#### **Mounting types NL and NR**

##### **Mechanical seal on the pressure side**

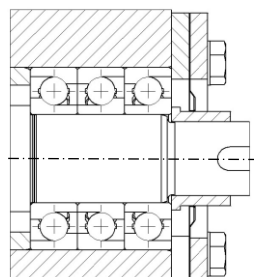

#### **Mounting types SL and SR**

##### **Mechanical seal on the suction side**

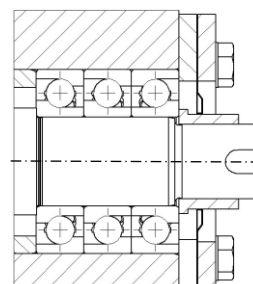

- Push the shafts (item 7) into the bearing housing (item 4). The lubrication holes of the needle bearings are directed upwards to ensure reliable venting.

ATTENTION



#### **Observe the installation position!**

Incorrect installation can lead to premature bearing damage and consequential damage.

DANGER



In potentially explosive atmospheres, bearings damages or consequential damages can lead to explosions.

- Mount the spacers (item 16)
- Assemble bearing covers with the slot facing downwards (item 14)
- Mount the NILOS ring (item 121) and bearing cover (item 15.)
- Fit lock washers (item 109) with hexagon bolts (item 110)
- Tighten the hexagon bolts (item 110)
- Rotate shafts and ensure that no grinding noises occur between NILOS rings (item 121) and spacers (item 16), readjust if necessary
- For pumps in bloc design:  
Mount gear wheel on drive side (item 13) and coupling half (item 300) with key (item 120), tension disk (item 12), spring washer (item 114) and hexagon bolt (item 115).
- For pumps with free shaft end:  
Mount the gear on the drive side (item 13) with key (item 120), lock washer (item 119) and locknut (item 118)
- Mount the driven gear (item 11) on the clamping bush (item 10) with hexagon head bolts (item 112), washers (item 111) and spring washer (item 113). The hexagon bolts (item 112) should be centered in the slotted holes of the gearwheel (item 11)
- Fit pre-assembled unit with key (item 120), tension washer (item 12), spring washer (item 114) and hexagon head screw (item 115)
- Press the radial sealing ring (item 106) into the bearing housing (item 4). The manufacturer's assembly tools should be used for this
- Install the product wetted parts of the pump in accordance with chapter 10.4 and chapter 10.7
- For pumps with free shaft end:  
Press the shaft seal (item 117) into the gear housing (item 5). The manufacturer's assembly tools should be used for this
- Fit gear housing (item 5) with flat gasket (item 128)
- Tighten cylindrical bolts (item 122)
- Mount the oil drain plug (item 19) and fill with gearbox oil via the inspection opening (item 30) up to the middle of the oil level gauge (item 129), for oil quality refer to chapter 7.2.2

## **10.7 Adjustment of flank clearance**

### ***For tightening torques refer to table 10.8***

The flank clearance is adjusted by clamping the driven gear (item 11) via the clamping bushing (item 10). The clamping bushing has slotted holes. The gear housing (item 05) does not need to be removed. If the following procedure is not successful, the feed screws are not positioned correctly (see chapter 10.4). This must then be corrected and the process restarted.

- Loosen the hexagon bolts (item 112) and thus the clamped connection between the gear wheel (item 11) and the clamping bushing (item 10). Do not remove the hexagon bolts (item 112) completely!
- Adjust the clearance between the feed screws (item 6) using the slotted holes in the clamping bush (item 10).
- Block the gear wheels (items 11 and 13) using a soft piece of metal

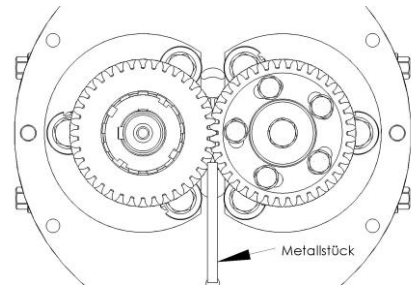
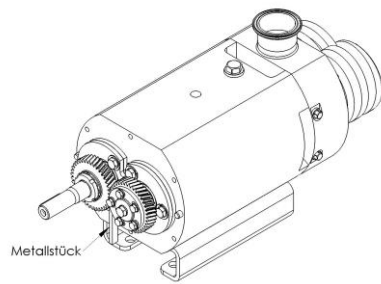

- Hold the driven shaft and use the driven shaft to mediate the clearance between the feed screws
- Tighten the hexagon head bolts (item 112)
- Check the clearance at several circumferential positions

### 10.8 Table of tightening torques

Designation	Item	Tightening torques per pump size [Nm]				
		50	70	90	105	125
Tension nut	18	24	58	180	190	430
Cap nut	100	15	24	50	65	90
Hexagon bolt	110	4	10	20	25	30
Hexagon bolt	112	7	10	20	20	55
Hexagon bolt	115	14	25	60	80	250
Cylindricalal bolt	122/133	5	5	10	10	18
Cylindricalal bolt	302	6	12	25	25	55

The items are not available on all pumps. The corresponding parts list must be taken into account here.

The following torques apply to other bolts, e.g. also for fastening motors to base plates.

#### Stainless steel bolts A70

Thread	M5	M6	M8	M10	M12	M16
Tightening torque [Nm]	2,5	5,5	12	25	45	100

#### Steel bolts 8.8

Thread	M5	M6	M8	M10	M12	M16
Tightening torque [Nm]	5	10	24	48	84	206

### 10.9 Clearances

The flank and circumferential clearances are determined by the dimensions of the components. The assessment of actual conditions depends on the application and is therefore case-specific. The manufacturer must be consulted for this.

## 11 Disposal

### 11.1 Disposal of the transport packaging

The transport packaging must be disposed of in accordance with local regulations or disposed of in the recycling collection system.

### **11.2 Disposal of lubricating oils and greases**

Lubricating oils or greases and parts containing them must be disposed of in accordance with local regulations.

### **11.3 Disposal of the pump or pump components**

Clean the pump or components carefully and dispose of the residues in accordance with local regulations. Pumps or assemblies must be dismantled into individual components. The individual parts must then be disposed of in accordance with the local regulations.

### **11.4 Disposal of electrical and electronic waste**

The components must be disposed of in accordance with local regulations.

## Appendix

This certificate must be completed and enclosed with every repair shipment to ensure safe handling of the pump.

### Clearance certificate

The pump and its accessories that we have sent for repair or inspection together with this clearance certificate:

Type: .....

Serial no: .....

Reason for the inspection or repair order: .....

- has not been used for / in hazardous liquids.
- was used at ..... and came into contact with liquids that require labeling or contain hazardous substances (safety data sheets attached).

Please specify the last funding medium: .....

The pump has been carefully emptied and cleaned inside and out using the cleaning agent ..... from the outside and inside.

- No special safety precautions are required for further handling.
- The following safety precautions regarding flushing liquids, residual liquids and disposal are required:

We assure you that the above information is correct and complete and that the shipment is carried out in accordance with the statutory provisions.

Company:

Department / contact person:

Phone:

Fax:

Street:

Postcode/ City

.....

Place / date / company stamp / signature

