

T100 Series High Pressure

Maximum Flow Rate: 98 l/min (26 gpm) 89l BPD
Maximum Pressure: 345 bar (5000 psi)

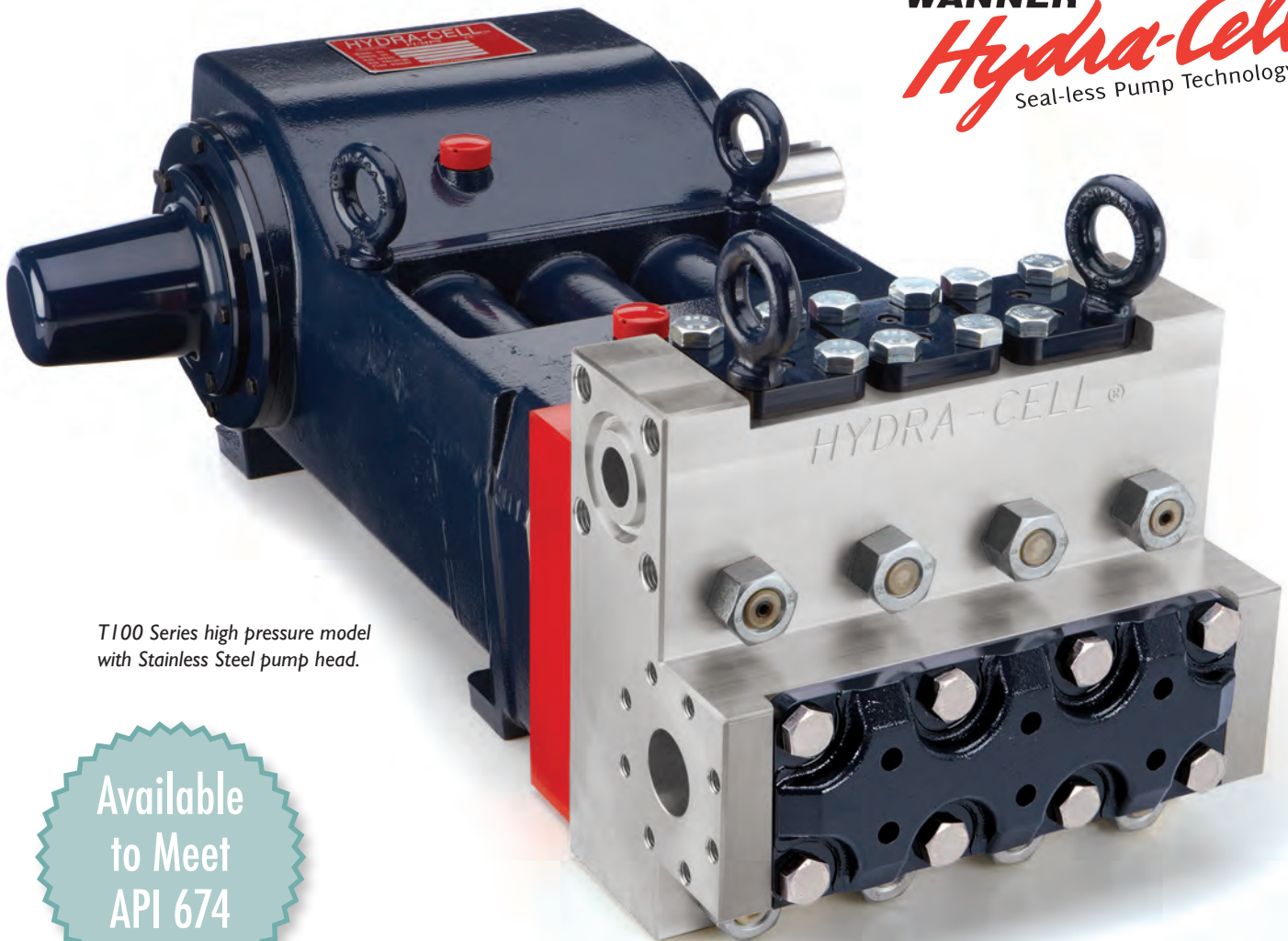

WANNER
Hydra-Cell
Seal-less Pump Technology



T100 Series high pressure model with Stainless Steel pump head.

Available
to Meet
API 674

- Seal-less design eliminates leaks, hazards and the expense associated with seals and packing.
- Low NPSH requirements allow for operation with a vacuum condition on the suction. Positive suction pressure is not necessary, and there is no need for a booster or charge pump.
- Patented Diaphragm Positioning Control (DPC) protects the diaphragms against a closed or blocked suction line.
- Can run dry indefinitely without damage, eliminating downtime and repair costs.
(Note: Intentional dry running not permitted in ATEX zones.)
- Unique diaphragm design handles more abrasives with less wear than gear, screw or plunger pumps.
- Hydraulically balanced diaphragms to handle high pressures with low stress.
- Significantly lower energy costs than centrifugal pumps.
- Rugged construction for long life with minimal maintenance.
- Compact design and double-ended shaft provide a variety of installation options.
- Hydra-Cell T100 Series pumps can be configured to meet API 674 Standards - consult factory for details.

T100 Series High Pressure Performance

Capacities

Model	Max. Input rpm	Plunger Dia.		Max. Flow Capacities			Max. Pressure Ratings Discharge		Max. Pressure Ratings Inlet	
		Inches	mm	gpm	l/min	BPD	psi	bar	psi	bar
T100S	450	1.375	35	26	98	891	5000	345	500	34

Consult factory when operating below 45 rpm.

Maximum Flow at Designated Pressure

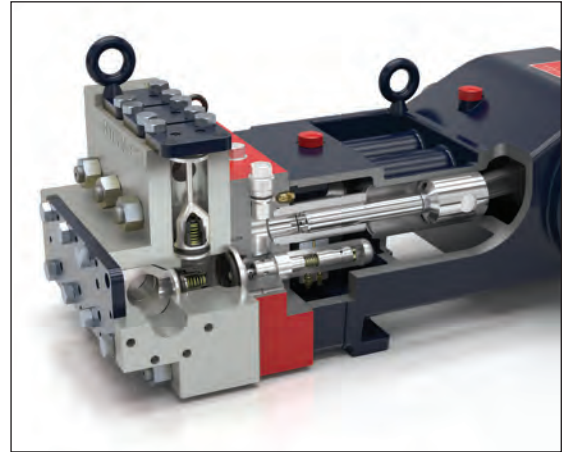
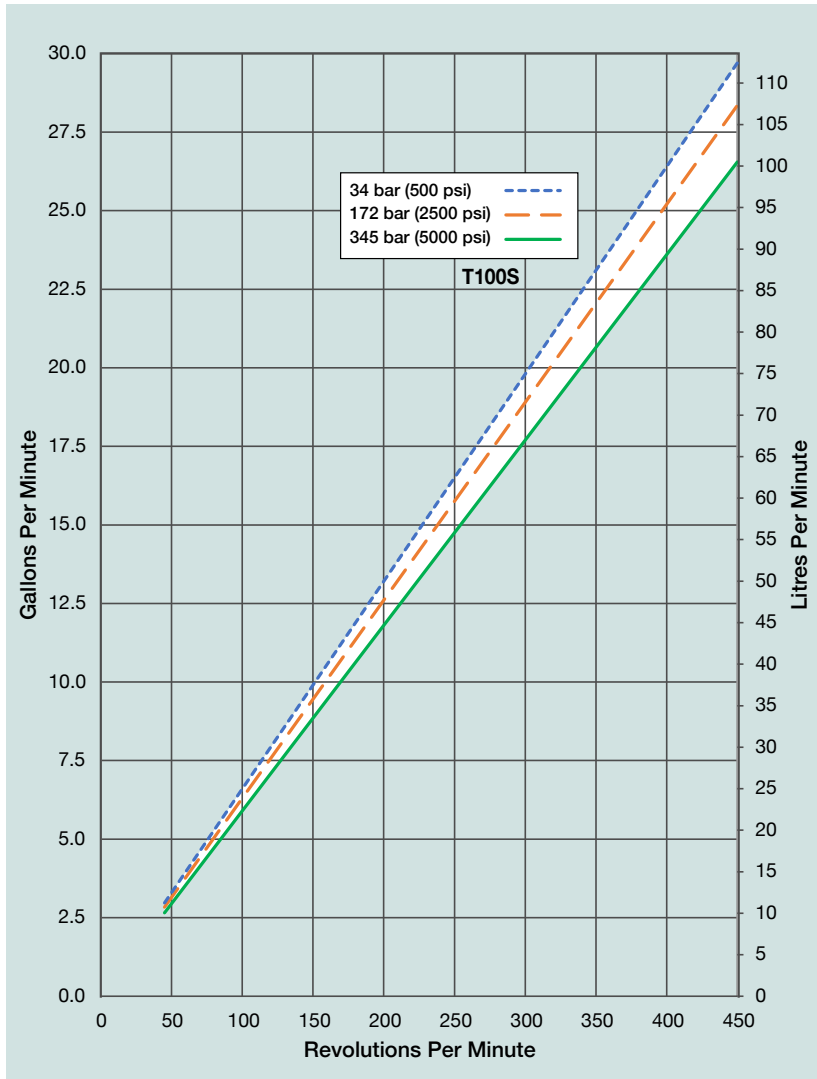

T100 Series pumps feature the Hydra-Cell seal-less design, eliminating clean-up costs from leaking seals or packing and protecting operators from dangerous fluids such as those containing hydrogen sulfide.

Due to the Wanner Engineering Continuous Improvement Program, specifications and other data are subject to change.

T100 Series High Pressure API 674 Performance

Capacities

Flow						Pressure	
Model	Max. Input rpm	Duty	Max. Flow @ 345 bar (5000 psi)			Maximum Inlet Pressure 34 bar (500 psi)	Maximum Discharge Pressure 345 bar (5000 psi)
			gpm	l/min	BPD		
T100	450	Intermittent	26	98	891		
	375	Continuous	22	83	754		

Consult factory when operating below 45 rpm.

Maximum RPM at Designated Pressure

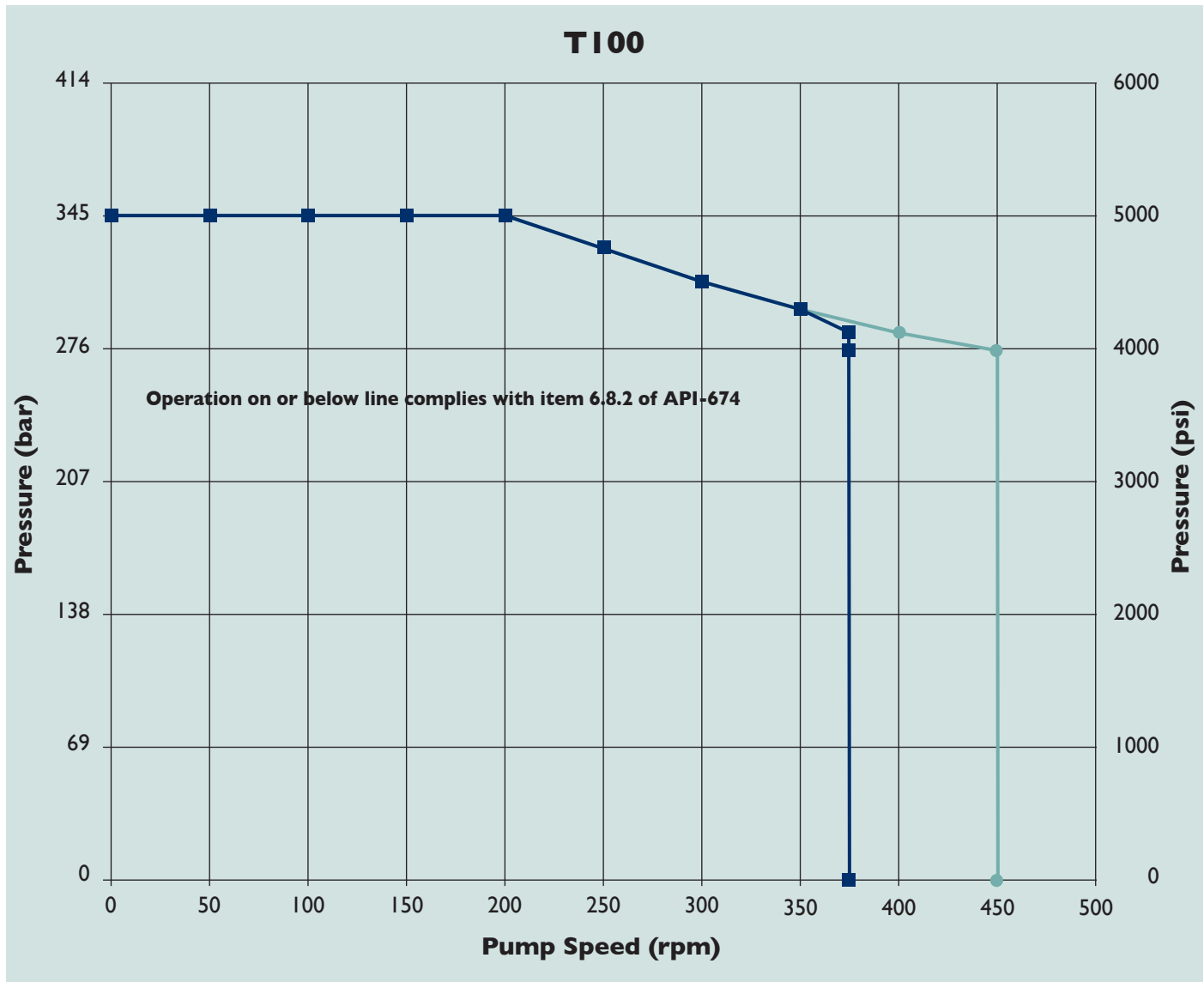

● Intermittent duty 1.375" plunger
Defined as up to 24/7 365 days pa

■ Continuous duty 1.375" plunger
Defined as 24/7 365 days pa

T100 Series High Pressure Specifications

Flow Capacities

Model	Pressure bar (psi)	rpm	gpm	l/min	BPD
T100S	345 (5000)	450	26	98	891

Delivery

	Pressure bar (psi)	gal/rev	litres/rev
T100S	34 (500)	0.066	0.249
	172 (2500)	0.063	0.237
	345 (5000)	0.059	0.222

rpm

Maximum:	450
Minimum:	45 (Consult factory for speeds less than 45 rpm.)

Maximum Discharge Pressure

Metallic Heads:	345 bar (5000 psi)
-----------------	--------------------

Maximum Inlet Pressure 34 bar (500 psi)

Operating Temperature Limits

Maximum Liquid Temperature:	82.2°C (180°F)
Diaphragm Material Minimum Service Temperature (Ambient & Liquid):	
Aflas	30°C
EPDM	-20°C
FKM	5°C
Buna-N (HBNR)	-5°C
Consult factory for temperatures outside of these ranges.	

Maximum Solids Size 800 microns

Input Shaft Left or Right Side

Inlet Ports 2 inch Class 300 FF ANSI Flange

Discharge Ports 1-1/4 inch Class 2500 RTJ ANSI Flange

Plunger Stroke Length 88.9 mm (3-1/2 inch)

Shaft Diameter 76.2 mm (3 inch)

Shaft Rotation Uni-directional (See rotation arrow.)

Oil Capacity 19.4 litres (20.5 US quarts)

See page 6 for oil selection and specification.

Weight

Metallic Heads: 499 kg (1100 lbs.)

Fluid End Materials

Diaphragm Follower Screw:	316 Stainless Steel
Outlet Valve Retainer:	316 Stainless Steel
Plug-Outlet Valve Port:	316 Stainless Steel
Inlet Valve Retainer:	316 Stainless Steel

See page 6 for customer-specified fluid end materials choices.

Power End Materials

Crankshaft:	Forged Q&T Alloy Steel
Connecting Rods:	Ductile Iron
Crossheads:	12L14 Steel
Crankcase:	Ductile Iron
Bearings:	Spherical Roller/Bronze Journal (outer mains) Steel Backed Babbit (crankpin) Bronze (wristpin, center mains)

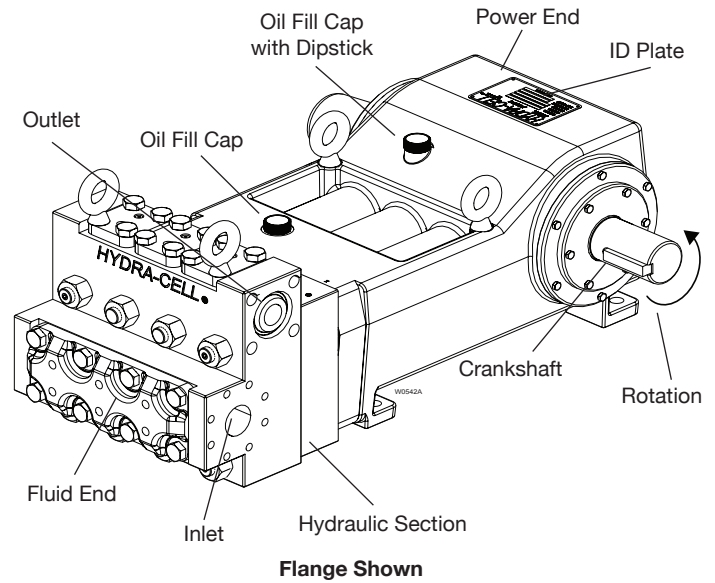

Net Positive Suction Head (NPSHr)

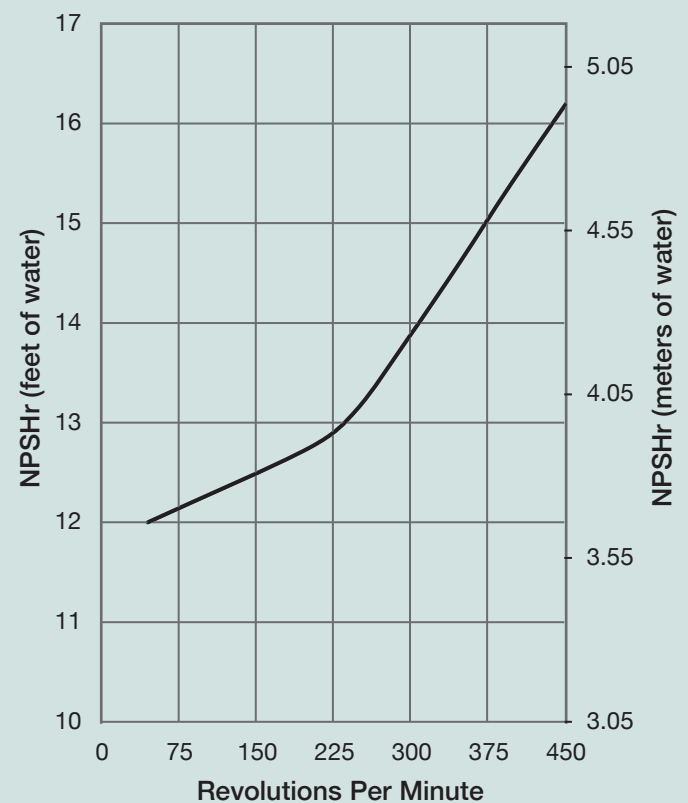

Calculating Required Horsepower (kW)*

$$\frac{\text{gpm} \times \text{psi}}{1,460} = \text{electric motor hp}^*$$

$$\frac{\text{lpm} \times \text{bar}}{511} = \text{electric motor kW}^*$$

* hp (kW) is required application power.

Attention!

When sizing motors with variable speed drives (VFD): It is very important to select a motor and a VFD rated for constant torque inverter duty service and that the motor is rated to meet the torque requirements of the pump throughout desired speed range.

T100 Series High Pressure Dimensions

Threaded Version inches (mm)

Front View

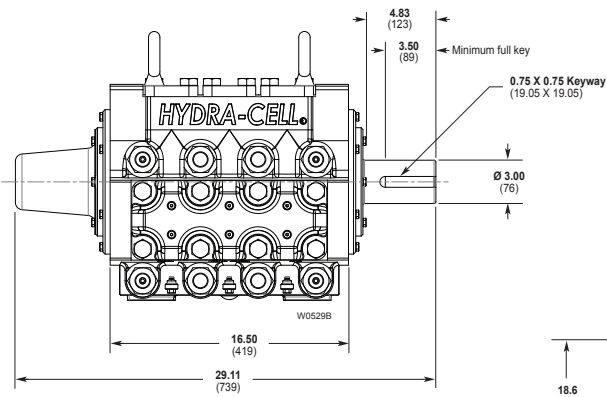

Side View

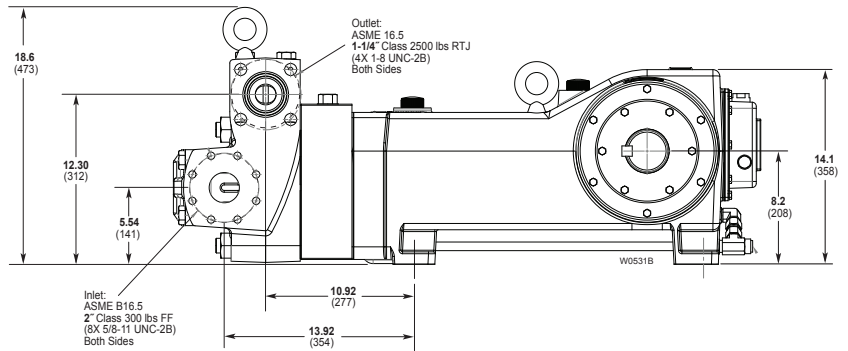

Top View

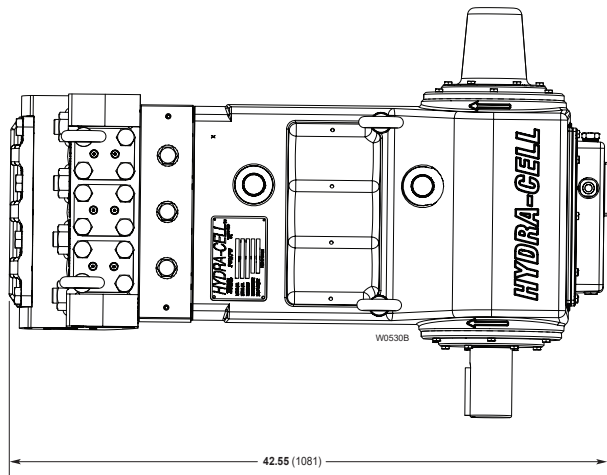

Bottom View

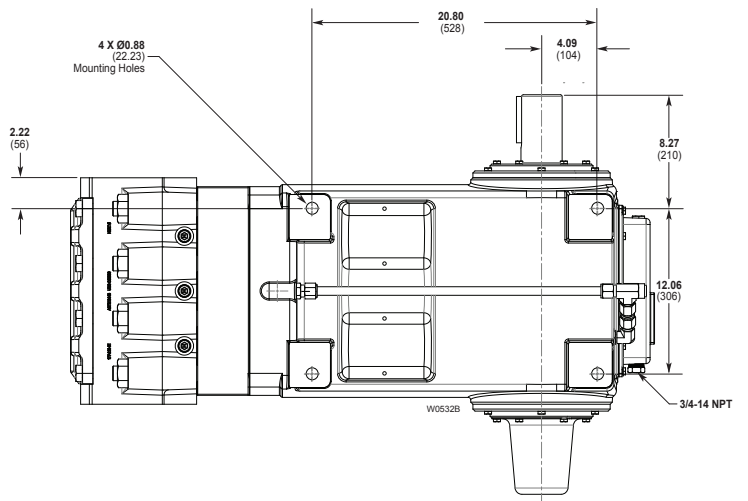

Note: Dimensions are for reference only. Contact Wanner International for certified drawings.

T100 Series High Pressure **How to Order**

Ordering Information

1	2	3	4	5	6	7	8	9	10	11	12	13	14
T	1	0	0	S	R								

A complete T100 Series High Pressure Model Number contains 14 digits including 8 customer-specified design and materials options, for example: T100SRDTHFEPAX.

High Pressure

Digit	Order Code	Description
1-4	T100	Pump Configuration Shaft-driven API 674 - Contact Wanner International
5	S	Performance Max. 98 l/min (26 gpm) 891 BPD @ 345 bar (5000 psi)
6	R	Pump Head Version ANSI Flange Ports (FF on Inlet / RTJ on Discharge)
7	D S	Pump Head Material Nickel Aluminium Bronze (NAB) 316L Stainless Steel
8	A E G T	Diaphragm & O-ring Material Atlas EPDM (requires EPDM-compatible oil - digit 13 code D) FKM Buna-N (HBNR)
9	D H N T	Valve Seat Material Tungsten Carbide* 17-4 Stainless Steel Nitronic 50 Hastelloy C
10	D F N T	Valve Material Tungsten Carbide* 17-4 Stainless Steel Nitronic 50 Hastelloy C
11	E T	Valve Springs Elgiloy Hastelloy C
12	M P S T	Valve Spring Retainers PVDF Polypropylene 316 SST Hastelloy C

*Tungsten Carbide valve seat and disc are a matched set and must be purchased together.

Digit	Order Code	Description
13	A B D E H	Hydra-Oil 10W30 standard-duty oil 40-wt. oil EPDM-compatible oil Food-contact oil 15W50 high-temp severe-duty synthetic oil
14	C O X	Oil Level Monitor Cover Float switch, normally closed (recommended) Float switch, normally open ATEX Certified Pump 2014/34/EU Zone 1 II 2/3 G Ex h IIC T5...T4 Gb/Gc With ATEX float switch

Note: The Oil Level Monitor Cover is an assembly that replaces the previous back cover on T100 Series pumps. It contains a float switch assembly that can trigger an alarm or shutdown when pre-defined levels of high or low oil are reached. It may also be ordered without a float switch cover.



T100 Series High Pressure



WANNER

Hydra-Cell[®]

Partners in over 70 Countries

Standards Compliance



 **Wanner International Ltd.**

**WANNER INTERNATIONAL
UNITED KINGDOM**

8 & 9 Fleet Business Park
Sandy Lane • Church Crookham
Hampshire UK GU52 8BF
t +44(0) 252 816847
e: sales@wannerint.com

 **Wanner Engineering, Inc.**

**WANNER ENGINEERING
WORLD HEADQUARTERS &
MANUFACTURING
Minneapolis USA**

t+1 612-332-5681
e: sales@wannereng.com

**REGIONAL OFFICE
Texas USA**

t+1 940-322-7111
e: sales@wannereng.com

**LATIN AMERICAN OFFICE
São Paulo, Brazil**

t +55 (11) 99582-1969
e: sales@wannereng.com

 **Wanner Pumps Ltd.**

**WANNER PUMPS
Kowloon HONG KONG**

t +852 3428 6634
e: sales@wannerpumps.com

Shanghai CHINA

t +86-21-6876 3700
e: sales@wannerpumps.com