

Q155 Series Medium Pressure

Maximum Flow Rate: 295 l/min (78 gpm) 2674 BPD
Maximum Pressure: 241 bar (3500 psi)



API 674



WANNER
Hydra-Cell[®]
Seal-less Pump Technology



Q155 Series medium pressure model
with Stainless Steel pump head.

Available
to Meet
API 674

- Seal-less design eliminates leaks, hazards and the expense associated with seals and packing.
- Low NPSH requirements allow for operation with a vacuum condition on the suction. Positive suction pressure is not necessary, and there is no need for a booster or charge pump.
- Patented Diaphragm Positioning Control (DPC) protects the diaphragms against a closed or blocked suction line.
- Can run dry indefinitely without damage, eliminating downtime and repair costs.
(Note: Intentional dry running not permitted in ATEX zones.)
- Unique diaphragm design handles more abrasives with less wear than gear, screw or plunger pumps.
- Hydraulically balanced diaphragms to handle high pressures with low stress.
- Significantly lower energy costs than centrifugal pumps.
- Rugged construction for long life with minimal maintenance.
- Compact design and double-ended shaft provide a variety of installation options.

Q155 Medium Pressure Performance

Capacities

Model	Max. Input rpm	Plunger Dia.		Max. Flow Capacities			Max. Pressure Ratings			
							Discharge		Inlet	
		Inches	mm	gpm	l/min	BPD	psi	bar	psi	bar
Q155K	450	1.750	44	78	295	2674	3000	207	500	34
Q155M	450	1.625	41	63	238	2160	3500	241	500	34

Consult factory when operating below 45 rpm.

Maximum Flow at Designated Pressure

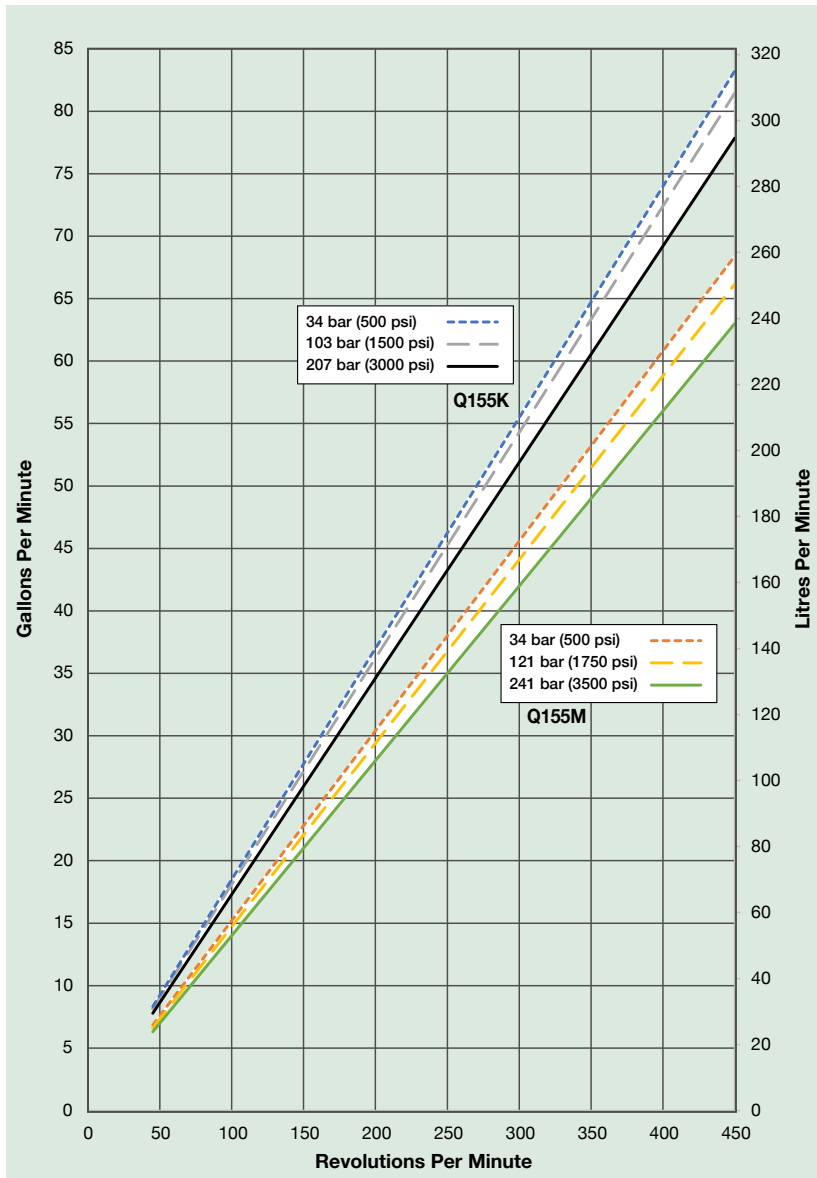

Note: Each pump complies with item 6.8.2 of API 674 across the full performance range.

Q155 Medium Pressure Specifications

Flow Capacities

Model	Pressure bar (psi)	rpm	gpm	l/min	BPD
Q155K	207 (3000)	450	78	295	2674
Q155M	241 (3500)	450	63	238	2160

Delivery

	Pressure bar (psi)	gal/rev	litres/rev
Q155K	34 (500)	0.185	0.700
	103 (1500)	0.181	0.685
	207 (3000)	0.173	0.654
Q155M	34 (500)	0.152	0.575
	121 (1750)	0.147	0.556
	241 (3500)	0.140	0.530

rpm

Maximum:	450
Minimum:	45 (Consult factory for speeds less than 45 rpm.)

Maximum Discharge Pressure

Metallic Heads:	Q155K	207 bar (3000 psi)
	Q155M	241 bar (3500 psi)

Maximum Inlet Pressure 34 bar (500 psi)

Operating Temperature Limits

Maximum Liquid Temperature:	82.2 °C (180 °F)
Diaphragm Material Minimum Service Temperature (Ambient & Liquid):	
Aflas	30 °C
EPDM	-20 °C
FKM	5 °C
Buna-N (HBNR)	-5 °C

Consult factory for temperatures outside of these ranges.

Maximum Solids Size	800 microns
Input Shaft	Left or Right Side
Inlet Ports	Weld-On: 4" / SCH. 40 4" NPT, 4" Class 300 RF ANSI Flange
Discharge Ports	Weld-On 2" / SCH. 160 2" NPT, 2" Class 2500 RTJ ANSI Flange
Plunger Stroke Length	88.9 mm (3-1/2 inch)
Shaft Diameter	76.2 mm (3 inch)
Shaft Rotation	Uni-directional (See rotation arrow.)
Oil Capacity	33.1 litres (35 US quarts) See page 5 for oil selection and specification.

Weight

Metallic Heads:	771 kg (1700 lbs.)
-----------------	--------------------

Fluid End Materials

Diaphragm Follower Screw:	316 Stainless Steel
Outlet Valve Retainer:	316 Stainless Steel
Plug-Outlet Valve Port:	316 Stainless Steel
Inlet Valve Retainer:	316 Stainless Steel

See page 5 for customer-specified fluid end materials choices.

Power End Materials

Crankshaft:	Forged Q&T Alloy Steel
Connecting Rods:	Ductile Iron
Crossheads:	12L14 Steel
Crankcase:	Ductile Iron
Bearings:	Spherical Roller/Journal (outer mains) Steel Backed Babbitt (crankpin) Bronze (wrist pin, center mains)

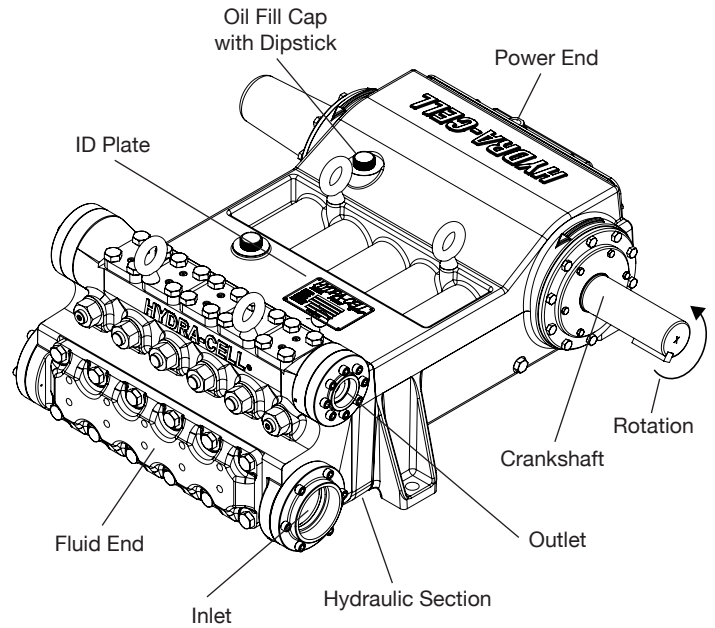

Net Positive Suction Head (NPSHr)

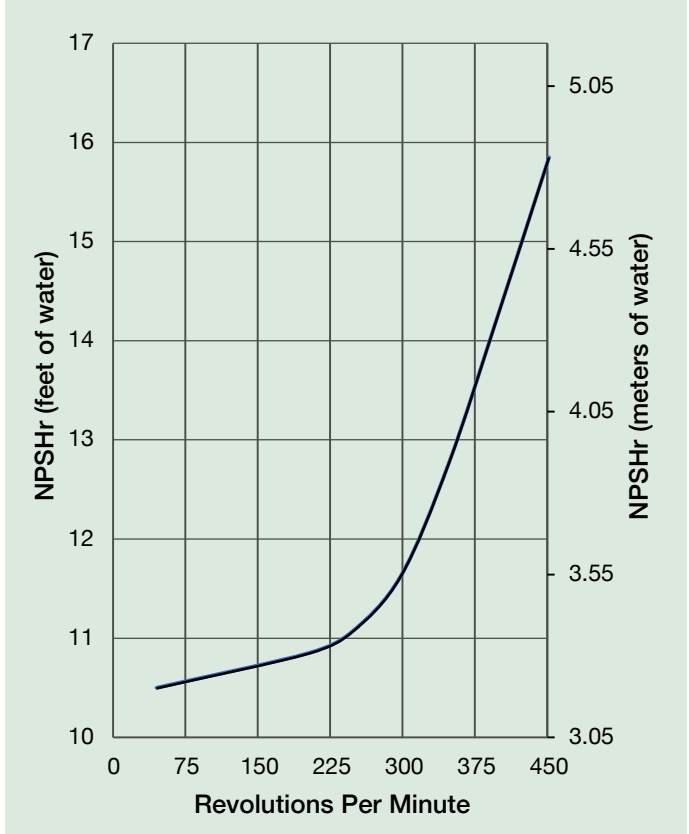

Calculating Required Horsepower (kW)*

$$\frac{\text{gpm} \times \text{psi}}{1,460} = \text{electric motor hp}^*$$

$$\frac{\text{lpm} \times \text{bar}}{511} = \text{electric motor kW}^*$$

* hp (kW) is required application power.

Attention!

When sizing motors with variable speed drives (VFD): It is very important to select a motor and a VFD rated for constant torque inverter duty service and that the motor is rated to meet the torque requirements of the pump throughout desired speed range.

Due to Wanner Engineering continuous improvement practices, performance data and specifications may change without notice.

Q155 Medium Pressure Dimensions

Threaded Version Inches (mm)

Front View

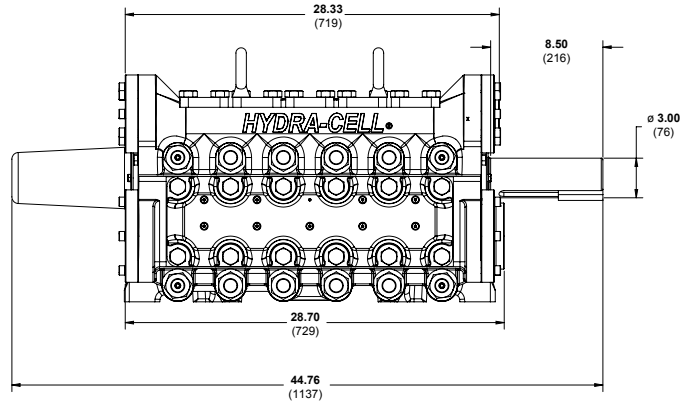

Side View

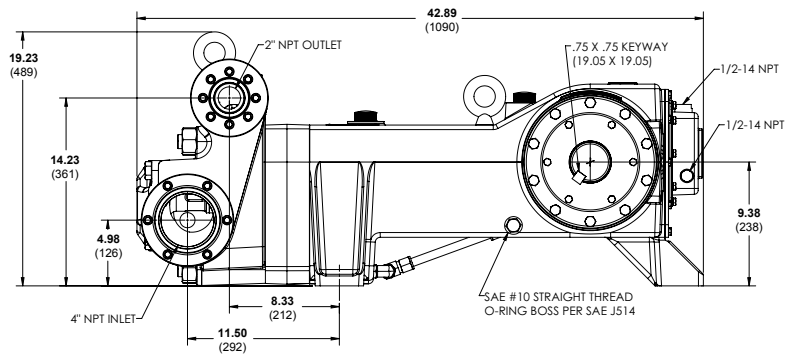

Bottom View

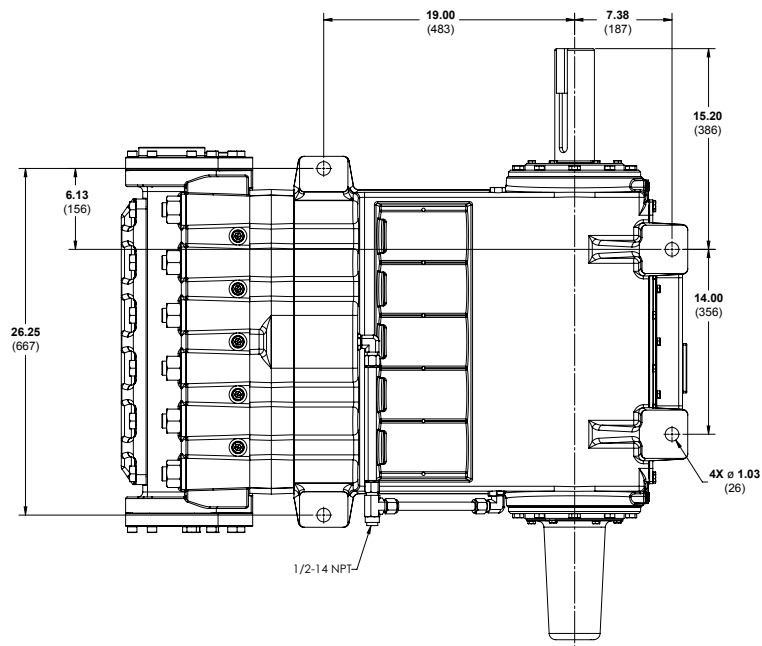

Note: Dimensions are for reference only. Contact Wannar International for certified drawings

Q155 Series Medium Pressure **How to Order**

Ordering Information

1 Q	2 1	3 5	4 5	5	6	7	8	9	10	11	12	13	14
---------------	---------------	---------------	---------------	----------	----------	----------	----------	----------	-----------	-----------	-----------	-----------	-----------

A complete Q155 Series Medium Pressure Model contains 14 digits including 10 customer-specified design and materials options, for example: Q155MADTTTETAC.

Medium Pressure

Digit	Order Code	Description
1-4	Q155	Pump Configuration Shaft-driven API 674 - Contact Wanner International
5	K M	Performance Max. 295 l/min (78 gpm) 2674 BPD @ 207 bar (3000 psi) Max. 238 l/min (63 gpm) 2160 BPD @ 241 bar (3500 psi)
6	A C D E F G R S T	Pump Head Version NPT Threaded Ports (Steel) Weld Neck (Steel) Weld Neck (316L Stainless Steel) Weld Neck (Hastelloy) Weld Neck (Duplex Alloy 2205 Stainless Steel) ANSI Flange Ports (Duplex Alloy 2205 Stainless Steel) ANSI Flange Ports (Steel) ANSI Flange Ports (316L Stainless Steel) ANSI Flange Ports (Hastelloy)
7	D G S T	Pump Head Material Nickel Aluminium Bronze (NAB) Duplex Alloy 2205 Stainless Steel 316L Stainless Steel C3FM Hastelloy CX2M
8	A E G T	Diaphragm & O-ring Material Aflas EPDM (requires EPDM-compatible oil - digit 13 code D) FKM Buna-N (HBNR)
9	D H N T	Valve Seat Material Tungsten Carbide* 17-4 Stainless Steel Nitronic 50 Hastelloy C
10	D F N T	Valve Material Tungsten Carbide* 17-4 Stainless Steel Nitronic 50 Hastelloy C

*Tungsten Carbide valve seat and disc are a matched set and must be purchased together.

Digit	Order Code	Description
11	E T	Valve Springs Elgiloy Hastelloy C
12	M P S T	Valve Spring Retainers PVDF Polypropylene 316 SST Hastelloy C
13	A B D E H	Hydra-Oil 10W30 standard-duty oil 40-wt. oil EPDM-compatible oil Food-contact oil 15W50 high-temp severe-duty synthetic oil
14	C O S T W X	Oil Level Monitor Cover Float switch, normally closed (recommended) Float switch, normally open Float Switch, CLS I DIV 1, normally closed Float Switch, CLS I DIV 1, normally open Float Switch, ATEX, analog Float Switch, ATEX, normally closed

Note: The Oil Level Monitor Cover is an assembly that replaces the previous back cover on Q155 Series pumps. It contains a float switch assembly that can trigger an alarm or shutdown when pre-defined levels of high or low oil are reached. It may also be ordered without a float switch cover.

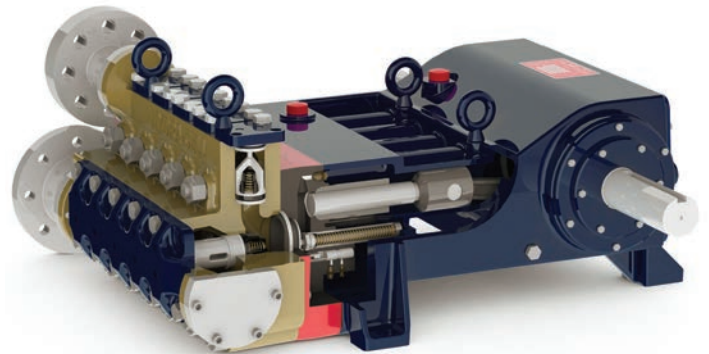

Q155 Series Medium Pressure



WANNER

Hydra-Cell[®]

Partners in over 70 Countries

Standards Compliance



 **Wanner International Ltd.**

**WANNER INTERNATIONAL
UNITED KINGDOM**

8 & 9 Fleet Business Park
Sandy Lane • Church Crookham
Hampshire UK GU52 8BF
t +44(0) 252 816847
e: sales@wannerint.com

 **Wanner Engineering, Inc.**

**WANNER ENGINEERING
WORLD HEADQUARTERS &
MANUFACTURING
Minneapolis USA**

t+1 612-332-5681
e: sales@wannereng.com

**REGIONAL OFFICE
Texas USA**

t+1 940-322-7111
e: sales@wannereng.com

**LATIN AMERICAN OFFICE
São Paulo, Brazil**

t + 55 (11) 99582-1969
e: sales@wannereng.com

 **Wanner Pumps Ltd.**

**WANNER PUMPS
Kowloon HONG KONG**

t +852 3428 6634
e: sales@wannerpumps.com

Shanghai CHINA

t +86-21-6876 3700
e: sales@wannerpumps.com