

## Air Operated Diaphragm Pump

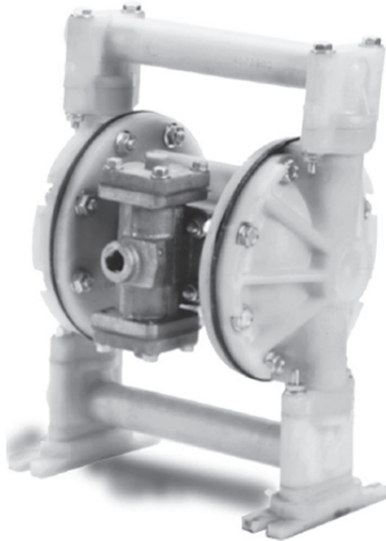

### FEATURES

- **Stall-Free Design** – Our “posi-shift”, tandem spool air distribution valve insures reliable operation in all types of low pressure and start/stop applications. In addition, fewer parts and no o-rings result in easier maintenance.
- **Oil-less Air Valve** – No metal-to-metal wearing surfaces. State-of-the-art materials and precision manufacturing techniques provide the industry’s original completely oil-less design. This design means no oil misting into the environment that would create an unhealthy working condition, and no oil, lubricants or grease to contaminate your products. Our oil-less design results in lower operating and maintenance costs. This design has been field proven and working trouble-free since 1984.
- **Externally Serviceable Air Valve** – No need to disassemble the pump for routine maintenance. The air valve can be quickly and easily maintained with minimal downtime.
- **Variety of Elastomers** - AOD® pumps can be assembled with the elastomer that matches your application; Neoprene, Buna-N, Nordel®, Teflon®, Santoprene®, and Viton® are all available.

## AOD.50 - \*(-P, -K)

### \*Pump Body Materials

- P - Polypropylene
- K - Kynar® (PVDF) †

### Elastomers

- Buna-N
- Neoprene
- Nordel®
- Santoprene®
- Teflon®
- Viton®

### Applications

- Aircraft Industry
- Automotive
- Beverage Industry
- Chemical and Petroleum
- Glass and Fiberglass
- Marine
- Metal and Steel
- Mine and Construction
- Paint
- Paper and Wood

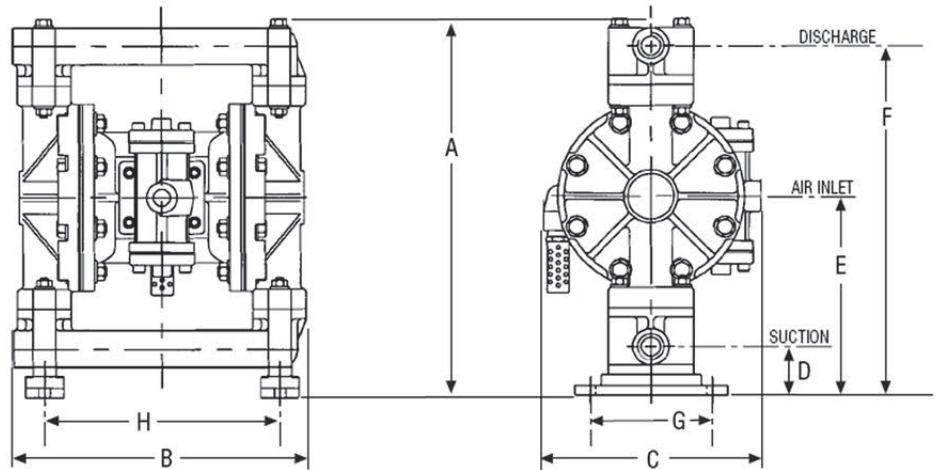

MODEL (Dimensions)		Polypropylene	Kynar®
		AOD.5-PxxP	AOD.5-KxxK
<b>SUCTION (Bottom)</b>	Inches	1/2 FNPT, BSP	1/2 FNPT, BSP
<b>DISCHARGE (Top)</b>	Inches	1/2 FNPT, BSP	1/2 FNPT, BSP
<b>A – Total Height</b>	Inches (mm)	12.38 (314)	12.06 (306)
<b>B – Total Depth</b>	Inches (mm)	9.56 (243)	9.38 (238)
<b>C – Total Width</b>	Inches (mm)	7.5 (191)	7.5 (191)
<b>Air Inlet Size</b>		<b>3/8" FNPT</b>	<b>3/8" FNPT</b>
<b>Air Exhaust Size</b>		<b>1/2" FNPT</b>	<b>1/2" FNPT</b>
<b>D – Suction Dimension</b>	Inches (mm)	1.63 (41)	1.63 (41)
<b>E – Air Inlet Dimension</b>	Inches (mm)	6.56 (167)	6.44 (164)
<b>F – Discharge Dimension</b>	Inches (mm)	11.5 (292)	11.31 (287)
<b>G – Mounting Dimension</b>	Inches (mm)	4 (102)	4 (102)
<b>H – Mounting Dimension</b>	Inches (mm)	7.69 (195)	7.69 (195)

NOTE: Pump dimensions may vary depending on configuration. Dimensions are to be used for reference only.



AOD® is a registered trademark of Price® Pump Co.; Teflon® is a registered trademark of DuPont; Viton® and Nordel® are registered trademarks of DuPont Dow Elastomers; Santoprene® is a registered trademark of Monsanto Company.

† Material is not ATEX certified.

# AOD.5 -P, -K

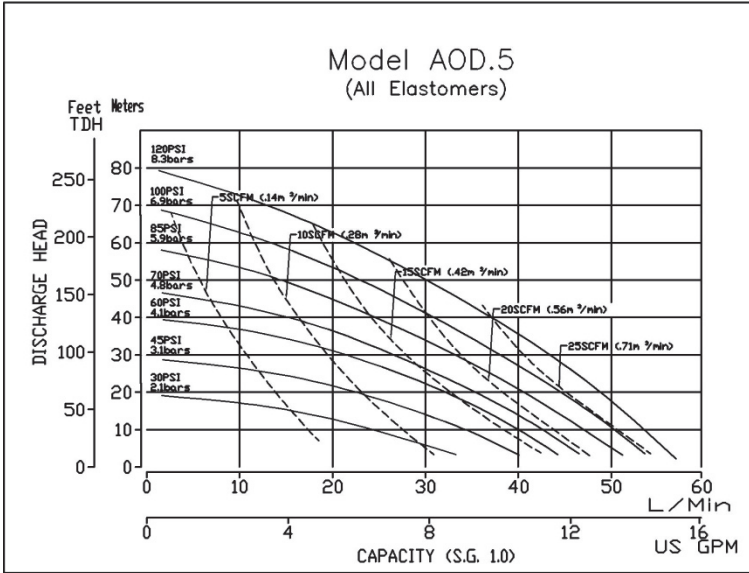

The performance curves shown and other published literature reflect an average performance for all materials and all elastomers, including Teflon®. Derating of the performance is not necessary for Teflon® fitted pumps.

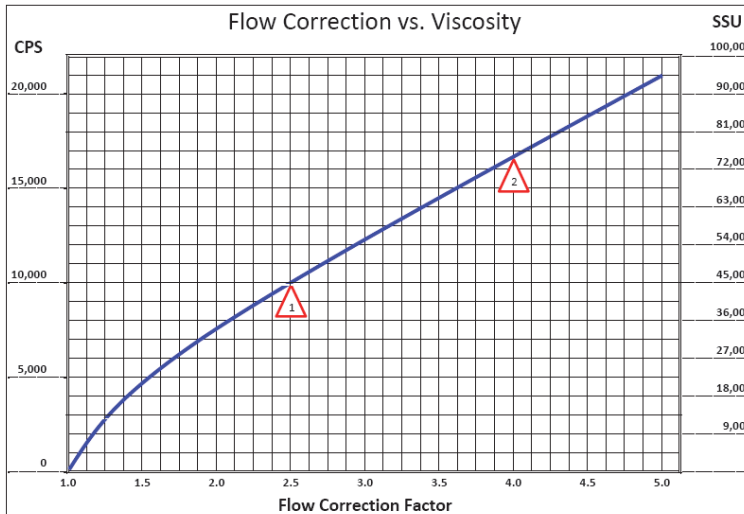

To determine the correction flow rate, find the intersection of the VISCOSITY on the above curve and read the FLOW CORRECTION FACTOR. Multiply this factor by the desired flow of the pump and use this new flow rate to select a pump from the performance curves.

Example  $\Delta$  10,000 CPS = 2.5 Flow Correction Factor.

If viscous flow desired is 42 GPM, then multiply 42 by 2.5 = 105 (GPM equivalent water flow)

Example  $\Delta$  74,000 SSU = 4.0 Flow Correction Factor.

If viscous flow desired is 35 GPM, then multiply 35 by 4.0 = 140 (GPM equivalent water flow)

## Technical Data

<b>Maximum flow</b>	GPM (liters per Minute)	15 (57)
<b>Displacement/Stroke</b>	Gal (liters)	
Elastomer Diaphragms		0.016 (0.06)
Teflon® Diaphragms		0.014 (0.05)
<b>Max Air Inlet Pressure</b>	PSI (bar)	125 (8.8)
<b>Max Spherical Solids Size</b>	IN (mm)	1/8 (3.2)
<b>High Liquid Temp. Limit</b>	*(See elastomer specs. below)	
<b>Low Temperature Limit</b>	°F (°C)	32 (0)
<b>Shipping Weight</b>	Lbs (kg)	
Polypro		39 (17.7)
Kynar®		39 (17.7)

## \*Elastomers

Maximum Liquid Temperature

MATERIAL	Polypro	Kynar®	Kit P/N
Buna-N	180°F (82°C)	180°F (82°C)	46-440-10
Neoprene	180°F (82°C)	180°F (82°C)	46-440-00
Nordel®	180°F (82°C)	180°F (82°C)	46-440-30
Santoprene®	180°F (82°C)	212°F (100°C)	46-440-60
Teflon®	180°F (82°C)	212°F (100°C)	46-440-55
Viton®	180°F (82°C)	248°F (120°C)	46-440-20

## Materials of Construction

<b>Air Valve Housing</b>	Polypro-glass filled
<b>Air Chambers</b>	Polypro-glass filled / Kynar®
<b>Spool Housing</b>	Electroless Nickel Coated Aluminum (**)
<b>Pump External Finish</b>	Natural (Not Painted)
<b>Valve Type</b>	Elastomeric Ball

\*\* - Optional 316 stainless steel, consult factory

## Suction Lifts

Elastomer Type (Material)	Dry Prime FT (meters)	Wet Prime FT (meters)
Standard	13 (4.0)	21 (6.4)
Teflon®	13 (4.0)	21 (6.4)

**PRICE PUMP CO.**

21775 Eighth Street East,  
Sonoma, CA 95476-0329  
MAIN (707) 938-8441  
TOLL FREE (800) 345-PUMP (7867)  
FAX (707) 938-0764  
[www.pricepump.com](http://www.pricepump.com)  
E-mail: [sales@pricepump.com](mailto:sales@pricepump.com)

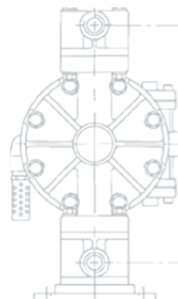

Member of:  
**Hydraulic INSTITUTE**

Your Local Price® Pump Distributor:

Rev. Date: Nov. 2010